

DiaMold[®]

Engis Polishing Products

MOLD/DIE POLISHING





POLISHING SOLUTIONS FROM ENGIS® CORPORATION

Engis® is a world leader in the manufacture of diamond polishing compound. In fact, the very first product manufactured by Engis® at its inception in 1938 was diamond compound for high precision military applications. We now not only have 80+ years of manufacturing experience behind us, but have complemented it with expertise in both diamond characterization and carrier chemistry. Our ISO 9001 quality certification ensures that Engis® brings strict disciplines to our manufacturing processes.

At the very core of the Engis® Corporation is our "Systems Approach". We not only offer quality products for sale, but we also provide complete solutions to our customers' application challenges. For the mold and die polishing market this involves: Diamond compounds as well as other polishing products, rotary and reciprocating hand tools, and operator experience and techniques.



Engis® truly is a single source for all of your polishing needs. Because we recognize that polishing is a system, Engis® offers a full range of high quality rotary and reciprocating tools as well as machine accessories and consumables.

We know that it is customer service that will differentiate Engis® from other suppliers. Our total commitment to our customers means that we service everything we sell. You can purchase from Engis® knowing you will have complete factory support for technical questions and repairs.

And, to complete the package of total customer service, we have experienced tool and die makers on staff who can draw upon their own time on the bench to assist you with your polishing challenges or in selecting the right product.

In summary, at Engis® it is our intent to go beyond being just a provider of quality products, but to partner with our customers to provide the best possible finishes in the shortest amount of time and at the lowest cost.





DIAMOND COMPOUNDS, POLISHING LUBRICANTS, & HIGH-INTENSITY POLISH

Section 1	Diamold® Diamond Compounds	5
	Hyprez® Lubricants	10
	Diamold® High Intensity Polish	11



DIPROFIL® FINISHING SYSTEMS, TOOLS, & ACCESSORIES

Section 2	Diprofil® Finishing Systems	13
	Diprofil® Classic Tools	14
	Diprofil® Di-Pro™ Reciprocating Tools	15
	Accessories for Classic and Di-Pro™ Tools	16
	Electric Hanging Motors & Accessories	19
	Bench Mount Motor Hangers	20
	Classic Diprofil® Tool Kits	21
	Foredom® Flex Shaft Rotary Handpieces	22
	Diprofil® Micro-Motor Rotary Handpieces	22
	Diprofil® Mini-Filing/Micro-Motor Systems	23
	Power Packs	25
	Diprofil® Ultrasonic System	26



DIPROFIL® FILES

Section 3	Diprofil® Diamond & Steel Files	27
	Diprofil® Precision Diamond Files	29
	Diprofil® Precision Hand Files	32
	Diprofil® Precision Machine Files	39
	Diprofil® Precision Steel Files	41



MINIMO® FINISHING SYSTEMS, TOOLS, & ACCESSORIES

Section 4	Minimo® One Series	43
	Minimo® Power Packs	45
	Minimo® Polytor Ultrasonic	46
	Minimo® Standard Rotary Handpieces	47
	Minimo® Slender Rotary Handpieces	50
	Minimo® Heavy Duty Rotary Handpieces	51
	Minimo® Rubron Systems	54
	Minimo® Anglon Systems	55
	Minimo® Recipron Systems	63
	Minimo® Mini-Belt Sander	64
	Minimo® Motors	66
	Minimo® Heads	67
	Minimo® Accessories	70
	Minimo® Tool Stand/ Rubber Cradle	72



ROTARY FINISHING TOOLS

Section 5	Rotary Finishing Tools	73
	Engis® Superabrasive Tools	82



FINISHING STICKS, STONES, & ACCESSORIES

Section 6	DiaMold® Lapping Sticks	85
	DiaMold® Polishing Stones	86
	DiaMold® Ceramic Stones	91
	DiaMold® Stone Holders	93
	Stones, Lapping Stick, & File Holders	94



WELDING UNITS & ACCESSORIES

Section 7	SST Microwelding	95
	Mold Medic Supplies	98

COMPOUNDS FOR EVERY APPLICATION

A comprehensive range of DiaMold® and Hyprez® Diamond Compounds for all variable involved in polishing. By using the proper compound, in conjunction with the proper equipment and accessories, you can be assured of consistent, repeatable results of the highest quality. Balancing our expertise in grading and micronizing of diamonds, along with knowledge of chemistry, compounding techniques, carrier formulations, and concentration factors, Engis® is able to offer every mold maker a compound to meet their specific need. Available in micron sizes from 1/10 to 60. Syringes sizes (grams): 5, 10, 18, 50, 100. Other container sizes are available.

DiaMold® Compounds



Formulated for general purpose use, an economic solution that delivers quality results in many mold & die applications.

Hyprez® L Compound



For use on harder materials, such as tungsten carbide tooling & ceramics due to enhanced surface tension properties. Withstands frictional heat generated during use.

Hyprez® W Compound



Water soluble formula that cleans easily from the workpiece. Suitable for high luster polishing, but which might be affected by an oil-based compound.

Hyprez® SC Compound

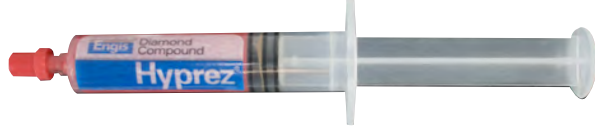

Superior lubrication properties that enhance cut rate without sacrificing finish. Adheres to workpiece/ tool. High vaporization point permits working on precooled molds.

Hyprez® Five-Star



Combines the excellent cutting characteristics of natural diamond with the durability of synthetic diamonds, into an all-purpose, precision blend. Clean up with either oil or water-based products. Eliminates polishing steps, resulting in better quality finish produced in less time.

	Chemistry		Materials				Performance		
	Oil Based	Water Based	Carbides	Tool Steels	Ceramics	Aluminum	High Luster/ High Performance	Toolroom Applications	General Purpose
DiaMold®	•			•					•
Five Star	•	•	•	•		•	•		
L Compound	•		•		•	•		•	
W Compound		•					•	•	•
SC Compound	•		•		•				

DiaMold® Compounds

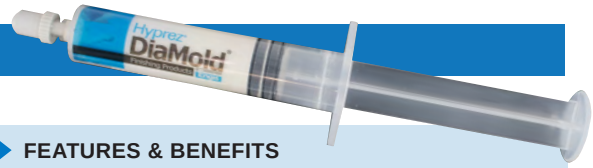

PREMIUM PERFORMANCE AT AN ECONOMICAL PRICE

Not every polishing application demands a superior performing product and many customers are on a tight budget. For general use, Engis® offers the DiaMold® range of diamond compound.

Manufactured to the same specifications as our premium Five-Star® compound, DiaMold® compound offers an economical solution for mold and die polishing applications.

DiaMold® diamond compound is oil soluble and can be used with Hyprelube® and Hyprez® OS Type IV (oil soluble) lubricants.

FEATURES & BENEFITS

- Economical
- Good surface tension
- Consistent viscosity
- Will not evaporate
- Oil based
- No odor
- Good adhesion to tools and surfaces
- Use with OS or Hyprelube® lubricant

AVAILABLE PACKAGING

- 10 gram syringe
- 20 gram syringe
- Call for other sizes

Micron Size	Product Code	Compound Color	Application	Concentration	10 Gram Part No.	20 Gram Part No.
1	1-DiaMold®	Ivory	Final Polishing	Standard	340.5120	340.5130
3	3-DiaMold®	Yellow	Final Polishing	Standard	340.5121	340.5131
6	6-DiaMold®	Orange	Lapping & Pre-Polishing	Standard	340.5122	340.5132
9	9-DiaMold®	Green	Lapping & Pre-Polishing	Standard	340.5123	340.5133
15	15-DiaMold®	Blue	Lapping & Pre-Polishing	Standard	340.5124	340.5134
30	30-DiaMold®	Red	Rapid Stock Removal	Standard	340.5125	340.5135
45	45-DiaMold®	Brown	Rapid Stock Removal	Standard	340.5126	340.5136
60	60-DiaMold®	Natural	Rapid Stock Removal	Standard	340.5127	340.5137

VALUE KITS

- 1 ea. 10 gram syringe 3, 6 & 9 (part no. 340.5144)
- 1 ea. 10 gram syringe 1, 3, 6 & 9 (part no. 340.5143)
- 1 ea. 10 gram syringe 9, 15 & 30 (part no. 340.5145)

DIAMOLD® FIVE-STAR® COMPOUND

The mold finisher's choice! Five-Star® compound is graded to closer tolerances than normal industry standards which results in faster and more consistent cut rates. Our Chemical Engineering Department has developed a carrier which offers superior finishes which can be cleaned with either oil or water based products.

The performance of Engis® Five-Star® compound often eliminates polishing steps, resulting in a better quality mold finish produced in less time.

2-Way Solubility: Five-Star® diamond compound can be used with Hyprez® OS Type IV (oil soluble) or Type W (water soluble) lubricants which offers maximum versatility.

FEATURES & BENEFITS



- **Faster cut rates**
- **Better finishes grit size to grit size**
- **Excellent surface tension**
- **Consistent viscosity**
- **Will not evaporate**
- **Excellent adhesion to tools and surfaces**
- **Easily cleaned with water or oil based products**
- **Offered in Medium, Standard and Strong concentrations**

AVAILABLE PACKAGING

- **5 gram syringe**
- **18 gram syringe**
- **Call for other sizes**

Micron Size	Product Code	Compound Color	Application	Concentration	5 Gram Part No.	18 Gram Part No.
1/10	1/10-FS/US	Gray	Final Polishing	Medium	204.1022	204.1023
				Standard	204.1024	204.1025
				Strong	204.1026	204.1027
1/4	1/4-FS/US	Gray	Final Polishing	Medium	204.1028	204.1029
				Standard	204.1030	204.1031
				Strong	204.1032	204.1033
1/2	1/2-FS/US	Gray	Final Polishing	Medium	204.1034	204.1035
				Standard	204.1036	204.1037
				Strong	204.1038	204.1039
1	1-FS/US	Ivory	Final Polishing	Medium	104.1254	104.1255
				Standard	104.1256	104.1257
				Strong	104.1258	104.1259
3	3-FS/US	Yellow	Final Polishing	Medium	104.1260	104.1261
				Standard	104.1262	104.1263
				Strong	104.1264	104.1265
6	6-FS/US	Orange	Lapping & Pre-Polishing	Medium	104.1266	104.1267
				Standard	104.1268	104.1269
				Strong	104.1270	104.1271
9	9-FS/US	Green	Lapping & Pre-Polishing	Medium	104.1272	104.1273
				Standard	104.1274	104.1275
				Strong	104.1276	104.1277
15	15-FS/US	Blue	Lapping & Pre-Polishing	Medium	104.1278	104.1279
				Standard	104.1280	104.1281
				Strong	104.1282	104.1283
30	30-FS/US	Red	Lapping & Pre-Polishing	Medium	104.1284	104.1285
				Standard	104.1286	104.1287
				Strong	104.1288	104.1289
45	45-FS/US	Brown	Lapping & Pre-Polishing	Medium	104.1290	104.1291
				Standard	104.1292	104.1293
				Strong	104.1294	104.1295
60	60-FS/US	Natural	Lapping & Pre-Polishing	Medium	104.1296	104.1297
				Standard	104.1298	104.1299
				Strong	104.1300	104.1301

HYPREZ® L COMPOUND

For tungsten carbide, hard metals, and ceramics. Hyprez® Formula L diamond compounds are specially formulated for use with harder materials. Typical applications include finishing tungsten carbide tooling, rolls and balls, ceramics and coarse lapping on Hyprez® natural metal and special composite laps.

Proven formulation! Hyprez® Formula L is a uniform diamond particle suspension which is not affected by dilution. The compound can be thinned to any desired consistence with Hyprez® OS Type IV and Hyprelube® lubricants. It utilizes a special tension to improve lap adhesion.

Withstands frictional heat! The consistence of Hyprez® Formula L is not affected by frictional heat generated during use. Only minimal lubrication is required for optimal results.

FEATURES & BENEFITS



- Formulated for carbide, ceramics, and hard metals
- Oil based
- Water based version available
- Offered in medium, standard, and strong concentrations
- Use with OS or Hyprelube® lubricant

AVAILABLE PACKAGING

- 5 gram syringe
- 18 gram syringe
- Call for other sizes

Micron Size	Product Code	Compound Color	5 Gram Part No.	18 Gram Part No.
1/10	0.10(L)STD-MA	Gray	101.1002	101.1003
1/4	0.25(L)STD-MA	Gray	101.1022	101.1023
1/2	0.5(L)STD-MA	Gray	101.1042	101.1043
1	1(L)MED-MA	Ivory	101.1062	101.1063
	1(L)STD-MA		101.1082	101.1083
	1(L)STR-MA		101.1102	101.1103
3	3(L)MED-MA	Yellow	101.1122	101.1123
	3(L)STD-MA		101.1142	101.1143
	3(L)STR-MA		101.1162	101.1163
6	6(L)MED-MA	Orange	101.1182	101.1183
	6(L)STD-MA		101.1202	101.1203
	6(L)STR-MA		101.1222	101.1223
9	9(L)MED-MA	Green	101.1242	101.1243
	9(L)STD-MA		101.1262	101.1263
	9(L)STR-MA		101.1282	101.1283
15	15(L)MED-MA	Blue	101.1302	101.1303
	15(L)STD-MA		101.1322	101.1323
	15(L)STR-MA		101.1342	101.1343
30	30(L)MED-MA	Red	101.1362	101.1363
	30(L)STD-MA		101.1382	101.1383
	30(L)STR-MA		101.1402	101.1403
45	45(L)MED-MA	Brown	101.1422	101.1423
	45(L)STD-MA		101.1442	101.1443
	45(L)STR-MA		101.1462	101.1463
60	60(L)MED-MA	White	101.1482	101.1483
	60(L)STD-MA		101.1502	101.1503
	60(L)STR-MA		101.1522	101.2121

HYPREZ® W COMPOUND

A water-soluble formula that cleans easily from the workpiece, Hyprez® W is recommended for areas requiring a very high luster, but which might be affected by an oil-base compound.

Hyprez® W was the first commercially successful diamond compound. Formulated by Engis®, it is still in general use by the die and mod industry and for precision hand lapping. For additional lubrication, use W lubricant.

FEATURES & BENEFITS



- Water based
- For parts requiring a higher luster
- Works great on 17-4 stainless
- Offered in medium, standard, and strong concentrations
- Use with W or Hyprelube® lubricants

AVAILABLE PACKAGING

- 5 gram syringe
- 18 gram syringe
- Call for other sizes

Micron Size	Product Code	Compound Color	5 Gram Part No.	18 Gram Part No.
1/10	0.10(W)475-MA (STD)	Gray	102.1002	102.1003
1/4	0.25(W)475-MA (STD)	Gray	102.1022	102.1023
1/2	0.5(W)475-MA (STD)	Gray	102.1042	102.1043
1	1(W)48-MA (MED)	Ivory	102.1062	102.1063
	1(W)47-MA (STD)		102.1082	102.1083
	1(W)45-MA (STR)		102.1102	102.1103
3	3(W)45-MA (MED)	Yellow	102.1122	102.1123
	3(W)40-MA (STD)		102.1142	102.1143
	3(W)35-MA (STR)		102.1162	102.1163
6	6(W)42-MA (MED)	Orange	102.1182	102.1183
	6(W)375-MA (STD)		102.1202	102.1203
	6(W)30-MA (STR)		102.1222	102.1223
9	9(W)40-MA (MED)	Green	102.1242	102.1243
	9(W)35-MA (STD)		102.1262	102.1263
	9(W)30-MA (STR)		102.1282	102.1283
15	15(W)40-MA (MED)	Blue	102.1302	102.1303
	15(W)35-MA (STD)		102.1322	102.1323
	15(W)30-MA (STR)		102.1342	102.1343
30	30(W)40-MA (MED)	Red	102.1362	102.1363
	30(W)30-MA (STD)		102.1382	102.1383
	30(W)20-MA (STR)		102.1402	102.1403
45	45(W)40-MA (MED)	Brown	102.1422	102.1423
	45(W)30-MA (STD)		102.1442	102.1443
	45(W)20-MA (STR)		102.1462	102.1463
60	60(W)35-MA (MED)	White	102.1482	102.1483
	60(W)30-MA (STD)		102.1502	102.1503
	60(W)25-MA (STR)		102.1504	102.1505

HYPREZ® SC COMPOUND

Super-cut compound gets the job done quicker! The new Hyprez SC diamond compound has been specifically formulated with the polishing professional in mind. In the past, a compound that cut quickly might leave a higher finish, resulting in additional finishing steps to massage the mold back to its original state. Any time saved on the front end was lost in the final polish; to address this challenge the engineers at Engis® have developed Hyprez® SC.

An exceptionally sharp diamond particle type has been selected and the PSD (particle size distribution) optimized for superior cutting action.

In addition, the chemists at Engis® have formulated a new carrier with special lubricating properties which enhance the cut rate without sacrificing finish. Taking into consideration that larger molds must often be polished in situ, the carrier has a high vaporization point, which permits working on molds which have not yet cooled. Hyprez® SC takes the compromise out of polishing. This breakthrough formula results in faster stock removal and fewer polishing steps which lead to lower costs, improved productivity, and better quality components.

Hyprez® SC has been tested at premiere mold shops around the Midwest with successful results.

FEATURES & BENEFITS

- New sharper diamond particles
- Optimized particle size distribution
- New carrier with superior lubrication qualities
- Better adhesion to the felt or wood bob
- Not “greasy” like standard compounds
- Easier to view the work piece while polishing
- Higher vaporization point

AVAILABLE PACKAGING

- 5 gram syringe
- 20 gram syringe
- Call for other sizes



Before and After photos of an A2 component finished with 3 micron SC compound on a felt wheel

Micron Size	Product Code	Compound Color	5 Gram Part No.	20 Gram Part No.
1	1(SC)STR	Ivory	500.1164	500.1168
3	3(SC)STR	Yellow	500.1174	500.1178
6	6(SC)STR	Orange	500.1124	500.1128
9	9(SC)STR	Green	500.1114	500.1118
20	20(SC)STR	Blue	500.1104	500.1108
30	30(SC)STR	Red	500.1134	500.1138
45	45(SC)STR	Brown	500.1144	500.1148
60	60(SC)STR	Natural	500.1154	500.1158

Hyprez® Lubricants

When selecting a lubricant for your application, care should be taken that it is chemically compatible with the compound formulation that you intend to use.



PRODUCT DETAILS

- Hyprelube®**
 Hyprelube® is a synthetic based lubricant formulated to be used with either our Five-Star® or our DiaMold® diamond compounds. This superior lubricant, with its penetrating qualities and oil/water solubility, not only increases the cutting action, but assures superior lubrication of every diamond particle throughout the polishing cycle.
- OS Type IV Lubricant**
 This low-viscosity, oil soluble lubricant is compatible with DiaMold® and other oil-based diamond compounds.
- W Lubricant**
 This water-based lubricant is compatible with Five-Star® and other water based compounds.

ALL HYPREZ® LUBRICANTS ARE AVAILABLE IN THE FOLLOWING CONTAINERS:

	Hyprelube® (Blue)	OS Type IV Lubricant (Purple)	W Lubricant (Yellow)
4 oz. glass bottle	510.HL.4OZ	510.2030	510.W.4OZ
1 pt. glass bottle	510.HL.1PT	510.2029	510.W.1PT
1 qt. glass bottle	510.HL.1QT	510.2028	510.W.1QT
1 gal.	510.HL.1GA	510.2162	510.W.1GA
5 gal.	510.HL.5GA	510.2063	510.W.5GA



HIGH INTENSITY POLISH

Diamond Compounds
Polishing Lubricants
High-Intensity Polish

DiaMold® High Intensity Polish

DiaMold® High Intensity Polish (HIP) safely removes haze, plate-out, oxidation and stains from any metal surface.

It's ideal for the final finish on all types of molds and dies resulting in a high luster sheen without any harsh odors.

Being easier to remove than other polishes, DiaMold® HIP wipes off quickly without leaving any residue.

In addition, it is non-hazardous and non-corrosive and will clean and remove haze from the mold surface without causing spiral webs, cattails or other types of fine scratches.

FEATURES & BENEFITS

- No harsh odors
- Easy application and removal
- Imparts a high polished finish with very little effort
- Can be used on typical mold steels as well as brass, bronze, chrome and aluminum
- Removes haze, rust, tarnish, dirt and oils
- Leaves protective film which retards oxidation and rust
- Non-abrasive diamond formulation

ORDERING GUIDE

Size	Part No.
5 grams	HIP.5.SYR
10 grams	HIP.10
50 grams	HIP.50
250 grams	HIP.250
500 grams (1/2 kilo)	HIP.500
1,000 grams (1 kilo)	HIP.1000



Diprofil® Finishing Systems
Tools
Accessories

Diprofil® Files

Minimo® Finishing Systems
Tools
Accessories

Rotary Finishing Tools

Finishing Sticks
Stones
Accessories

Welding Units
Accessories

DIAMOLD LABORATORY

DiaMold®

Engis Polishing Products

Located in our Technical Center, the Diamold Laboratory is available to all customers for a "hands-on" opportunity to try our various hand tools, diamond compounds & lubricants, polishing accessories, and microwelder.

- Experiment with different compounds
- Demonstrations for polishing or welding
- Authorized service center for hand tools & power packs
- Training

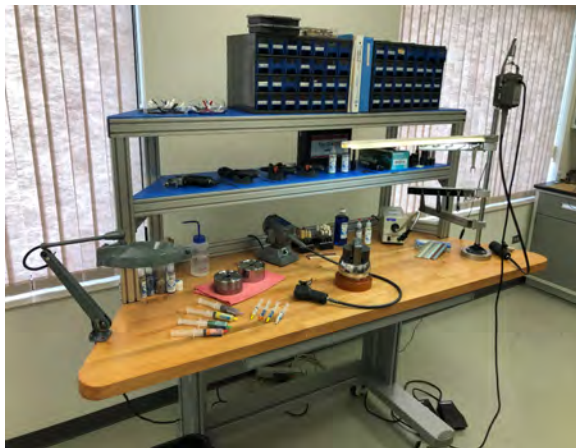



DIPROFIL® FINISHING SYSTEMS

Diamond Compounds
Polishing Lubricants
High-Intensity Polish

Diprofil® Finishing Systems

Engis® Corporation is proud to be a valued distributor of Diprofil® Finishing Systems and the **exclusive factory authorized repair facility for all Diprofil® reciprocating and rotary tools**. Our relationship with Diprofil® goes back more than 50 years, making Engis® the oldest Diprofil® distributor in North America.

In addition to the Diprofil® Classic Series, often imitated but never equaled, we stock the new Di-Pro™ low vibration tools, Dipromini mini polishing machines, rotary tools and accessories.

The Diprofil® brand is well known for its robust construction, high torque, reliability and precision. Many Diprofil® tools see decades of service before requiring any type of repair. Not only does Engis® stock spare parts, but our technicians can give rapid turnaround on any warranty or service work. No other Diprofil® distributor can deliver on this promise!

So, for all of your Diprofil® reciprocating and rotary tool requirements, questions or service, contact the professionals at Engis® Corporation.

AUTHORIZATION

DIPROFIL®
Engis® Corporation has been authorized as

AUTHORIZED DIPROFIL® SERVICE CENTER

Certified by:
Tomas Skeppmark
Managing Director, Diamantprodukter AB

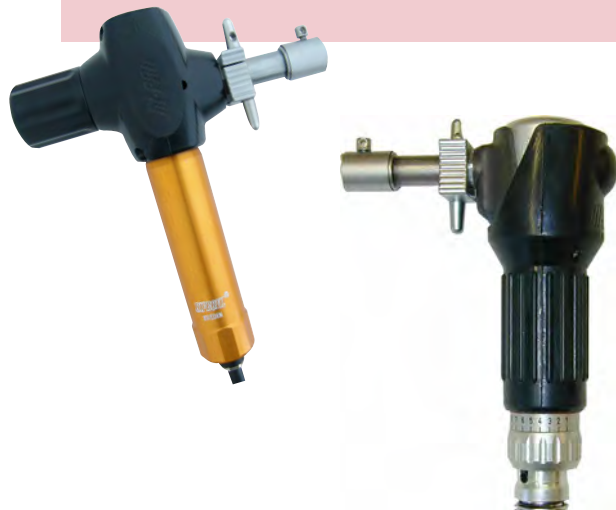

DIPROFIL® - TABLE OF CONTENTS

Product	Page
Classic Reciprocating Polishing/Filing Tools	14
Di-Pro Low Vibration Reciprocating Tools	15
Accessories for Classic and Di-Pro Tools	16
Electric Hanging Motors & Accessories	19
Bench Mount Motor Hangers	20
Classic Tool Sets	21
Flex Shaft Driven Rotary Handpieces	22
Micro-Motor Driven Rotary Handpieces	22
Mini-Filing/Micro-Motor Systems	23
Power Packs	25
Diprosonic Ultrasonic System	26

Diprofil® Finishing Systems
Tools
Accessories

Diprofil® Files

Minimo® Finishing Systems
Tools
Accessories

Rotary Finishing Tools

Finishing Sticks
Stones
Accessories

Welding Units
Accessories

Diprofil® Classic Tools

CLASSIC RANGE OF RECIPROCATING POLISHING/FILING TOOLS

The Classic Series is the original reciprocating filing tool designed as an efficient, fast, precise tooling system to replace tedious hand operations. Each tool is lightweight with sturdy construction, enabling operators to perform even delicate work on intricate parts with ease. The Classic Series is easy to operate and performs operations such as filing, honing, polishing and lapping of both straight and curved surfaces.

Classic tools have been the benchmark of quality tooling to mold and die making for many, many years.

Each model is fit with an ergonomic rubber sleeve for maximum operator comfort!

FPS/R



FPH/R



FPL/R



Motor	Flexible Shaft with ball joint	Flexible Shaft with ball joint	Air
Driver	Key hole	Square hole	Lubricated Compressed Air
Tool Holder	Dia. 6.4 mm	Dia. 6.4 mm	Dia. 6.4 mm
Stroke Length - Maximum	0 - 6mm	0 - 6mm	0 - 6mm
Stroke Length - Recommended	0.5 - 3mm	0.5 - 3mm	0.5 - 3mm
Speed - Maximum	8,000 rpm	8,000 rpm	8,000 rpm
Speed - Recommended	5,000-7,000 rpm	5,000-7,000 rpm	5,000-7,000 rpm
Weight	585 - 615 g	585 - 615 g	750 - 780 g
Noise	<70 dbA @ 6,000 rpm	<70 dbA @ 6,000 rpm	<70 dbA @ 6,000 rpm
Vibration	4 - 12 m/s ²	4 - 12 m/s ²	4 - 12 m/s ²

Frequency weighed hand/arm vibration principally in accordance with ISO 28927-8.
For further details refer to Operation Guide.

Diprofil® Di-Pro™ Reciprocating Tools

DI-PRO™ MARK II - RANGE OF LOW VIBRATION RECIPROCATING TOOLS

The Di-Pro™ polishing/filing machines represent a commitment from Diprofil® to greater operator comfort and safety. The Di-Pro™ series has been engineered with an enhanced ergonomic design to greatly reduce vibration while, at the same time, providing adequate torque and reciprocation levels to get the job done right. With Di-Pro™, you don't need to sacrifice performance in order to improve comfort and safety!



Each model is fit with an ergonomic rubber sleeve for maximum operator comfort!



Motor	Electric: <ul style="list-style-type: none"> Driven by electrical motor with speed control, ie Diprofil® type DSE-47 & flexible shaft with ball joint connection. Corresponding motors of other brands may also be used. 	Air: <ul style="list-style-type: none"> Should be driven by compressed air & oil mist lubricated air. The built-in air motor may be damaged if operated with unlubricated air.
Tool Holder	ø6.4mm	ø6.4mm
Stroke Length - Maximum	0 - 6mm	0 - 6mm
Stroke Length - Recommended	0.5 - 3mm	0.5 - 3mm
Speed-Maximum	7,000 rpm	7,000 rpm
Speed - Recommended	5,000 - 6,000 rpm	5,000 rpm
Weight	700 g	920 g
Noise	<75 dbA @ 7,000 rpm	<75 dbA @ 7,000 rpm
Vibration	<2.5 m/s ²	<2.5 m/s ²
Spare Parts List	http://diprofil.com/wp-content/uploads/2015/03/FXS-N-complete.pdf	http://diprofil.com/wp-content/uploads/2015/03/FXL-N-complete.pdf

It is important not to exceed the maximum tool input speed specified by the manufacturer.

Tools have been designed in accordance with ISO 28927-8 to minimize hand/arm vibration. For further details see diagram and other information in the Operation Guide.

Please note, the air-driven tool requires a quick coupling (HSLM) as well as an MFB Dipro-Fog lubricator. The air motor is manufactured to a precise level of accuracy and requires lubrication & filtered air (to 5 microns) to assure trouble-free operation.

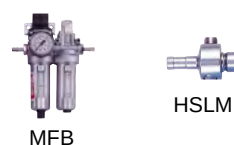

Accessories for Classic and Di-Pro™ Tools

UNIVERSAL TOOL HOLDER FMR/VH

Designed for Diprofil® polishing/filing machines. Great choice for holding DiaMold® polishing stones.

FEATURES

- Stainless steel hardened shank - 3mm (1/8")
- Shank length - approximately 35mm (1.375")
- Maximum tool thickness - 6mm (.236")



LIGHTWEIGHT TOOL HOLDER THPS-3

The reduced mass design of this tool holder suppresses potentially harmful vibrations from the stoning operation. Designed to be used with Diprofil® reciprocating machines and polishing stones with a thickness of 3mm (1/8").

FEATURES

- Stone thickness capacity - 3mm (1/8")
- Steel hardened shank - 3mm (1/8")
- Shank length - approximately 18mm (11/16")
- Total tool holder length - 31.5mm (1-1/4")
- Jaw width - 8mm (5/16")
- Weight - 3.9g



LIGHTWEIGHT TOOL HOLDER THFS-1

The reduced mass design of this tool holder suppresses potentially harmful vibrations from the stoning operation. Designed to be used with Diprofil® and other high frequency ultrasonic machines using ceramic stones with a thickness of 1mm (.039").

FEATURES

- Ceramic stone thickness capacity - 1mm (.039")
- Steel hardened shank - 3mm (1/8")
- Shank length - approximately 18mm (11/16")
- Total tool holder length - 31.5mm (1-1/4")
- Jaw width - 8mm (5/16")
- Weight - 4.3g



PROTECTIVE FINGER SLEEVES PFS-3.5 AND PFS-6.4

The PFS-3.5 and PFS-6.4 Protective Finger Sleeves are designed to fit your existing Diprofil® Classic and Di-Pro Series machines. This attachment covers the reciprocating tool rods and greatly reduces hand injuries during sustained tool operation.

FEATURES

- PFS-3.5 fits machines with a 3.5mm tool capacity
- PFS-6.4 fits machines with a 6.4mm tool capacity

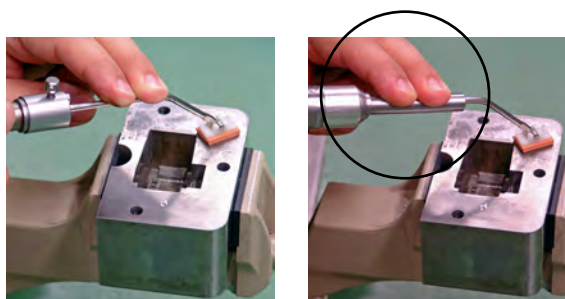

Old (wrong way) → New (correct way)

FNAK LUBRICATING OIL FOR DIPROFIL® TOOLS

FNAK Lubricant is specially formulated for use on external oil points on Diprofil® hand tools. When used properly this oil will reduce wear and prolong the life of your Diprofil® reciprocating polishing/filing machines.

Part No.	Container Size	MSDS
FNAK	20 ml / .67 oz	659
FNAK-0.5	1/2 liter / 16.9 oz	659



Please note: It is recommended that you read and follow the procedures outlined in the manufacturer's Operation Guide sent with each tool as they may require daily, as well as hourly, lubrication.

MFB DIPRO-FOG IN-LINE AIR FILTER/ LUBRICATOR/ REGULATOR/ MANOMETER

When using any Diprofil® air operated tool, the MFB In-Line Air Lubricator is a MUST. The MFB not only serves as a micro particle air filter, but keeps the pressure constant and the unit lubricated. The MFB set includes tubing and a bottle of MFAK tool lubricant. We also recommend ordering the HSLM quick release hose connector when using Diprofil® air operated tools.

TECHNICAL DATA

- Max. primary pressure: 16 bar / 232 psi
- Max. capacity at 7 bar: 1200 l/min
- Hose connection: 7mm / .275"
- Secondary pressure: 0.5 – 10 bar / 7 - 145 lbs



Please note: If your shop air has heavy contamination of dirt, oil, or water, it is advisable to add a larger pre-filter to reduce contamination to 5 micron.

MFAK DIPRO-FOG LUBRICANT

The Dipro-Fog MFAK Oil is specially developed for the unique lubricating requirements of the Diprofil and the Air Rotary Handpieces through the Dipro-Fog MFB Air Lubricator.

Part No.	Container Size	MSDS
MFAK	1/2 liter / 16 oz	659



HSLM QUICK RELEASE HOSE CONNECTOR

Each air-driven machine requires a quick coupling connector (type HSLM) as well as a Dipro-Fog lubricating device (MFB) to ensure sufficient lubrication at all times.





DEMONSTRATION

To view a Diprofil® demonstration, visit www.diprofil.com/diprofil-english/videos/



Electric Motors & Accessories

M.TX-SXR Kit	M.LXH-TXR Kit	M.TX-TXR Kit
<p>High Torque / Low Speed Key Drive Type 1/3 HP 15,000 maximum rpm Ball Bearing Design 115V Electrical Plug</p> 	<p>High Torque / Low Speed Square Drive Type 1/10 HP 5,000 maximum rpm Ball Bearing Design 115V Electrical Plug</p> 	<p>Extra Torque / High Speed Key Drive Type 1/3 HP 15,000 maximum rpm Ball Bearing Design 115V Electrical Plug</p> 
<p>Includes:</p> <ul style="list-style-type: none"> M.TX Hang Up Style Motor C.SXR-1 Cast Iron Foot Pedal Outer Sheath #S-77 (36-1/4" long) Inner Key Drive Shaft S-93 (39" long) 	<p>Includes:</p> <ul style="list-style-type: none"> M.LX Hang Up Style Motor C.TXR-1 Plastic Foot Pedal Heavy Duty Outer Sheath #S-10801TX (63" long) Inner Shaft #S-10823 (63-3/4" long) 	<p>Includes:</p> <ul style="list-style-type: none"> M.TX Hang Up Style Motor C.TXR-1 Plastic Foot Pedal Outer Sheath #S-77 (36-1/4" long) Inner Key Drive Shaft S-93 (39" long)
<p>Replacement Parts:</p> <ul style="list-style-type: none"> C.SXR-1 Speed Control (foot pedal) Outer Sheath #S-77 (36-1/4" long) Inner Key Drive Shaft #S-93 (39" long) MP319P Motor Brushes & Brush Caps 	<p>Replacement Parts:</p> <ul style="list-style-type: none"> C.TXR-1 Speed Control (foot pedal) Heavy Duty Outer Sheath #S-10801TX (63" long) Inner Shaft #S-10823 (63-3/4" long) MP319P Motor Brushes & Brush Caps 	<p>Replacement Parts:</p> <ul style="list-style-type: none"> C.TXR-1 Speed Control (foot pedal) Outer Sheath #S-77 (36-1/4" long) Inner Key Drive Shaft #S-93 (39" long) MP319P Motor Brushes & Brush Caps
<p>Hand Tools That Use M.TX-SXR:</p> <ul style="list-style-type: none"> FXS-N Di-Pro Machine (page 11) FPS/R Classic Machine (page 10) 	<p>Hand Tools That Use M.LX:</p> <ul style="list-style-type: none"> H.30H, H.44T 	<p>Hand Tools That Use M.TX-TXR:</p> <ul style="list-style-type: none"> FPS/R

C.EMX-1 RHEOSTAT DIAL SPEED CONTROL



Solid state motor speed control offers precise adjustment of motor speed and maintains speed for the operator unlike a foot pedal that requires constant foot pressure.

Bench Mount Motor Hangers

MAMH-2 BENCH TOP SCREW MOUNT

The Telescoping Motor Hanger is designed for fast and easy height and swivel adjustment by way of pole screws.

The pole base flange mounts permanently to your workbench top by three screws providing secure stable mounting. (Motor not included.)



MAMH-1 BENCH TOP CLAMP MOUNT

This motor hanger allows you the flexibility to move the hanger assembly easily to any bench location by way of its screw clamp (2 1/4" capacity).

It also includes rest for #30 or #44 handpieces. (Motor and handpieces not included.)

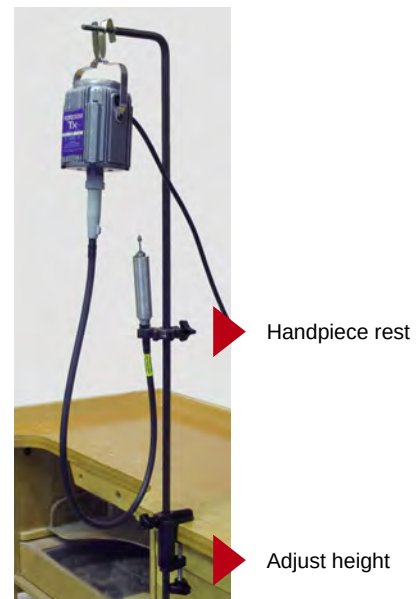

MAHH-30 BENCH HANDPIECE HOLDER CLAMP

The MAHH-30 provides a secure bench-top mounting of handpieces #30 and #44 (see page 18).

With the handpiece firmly held to the bench top, the operator has both hands free to hold and control the workpiece during grinding or polishing operations. (Handpiece not included.)



Classic Diprofil® Tool Kits

DS4 - FPS/R CLASSIC TOOL WITH KEY DRIVE KIT (39" CABLE)

SET INCLUDES:

- FPS/R: Classic Diprofil® Tool with Key Drive
- M.TX-TXR: Drive motor with key drive flex shaft & foot control
- MAMH-1: Bench clamp motor hanger
- C.TXR-1: Foot pedal
- S-77: Outer sheath
- S-93: Inner key drive shaft
- MP319P: Motor brushes & caps

FEATURES

- Tool holder: 6.4 mm / 1/4"
- Stroke length: 0-6 mm / 0-.235"
- Motor: 5,000 rpm



DS5 - FPH/R CLASSIC TOOL WITH SQUARE DRIVE KIT (HEAVY DUTY 63" CABLE)

SET INCLUDES:

- FPH/R: Classic Diprofil® Tool with Square Drive
- M.LXH-TXR: Drive motor with square drive flex shaft and foot control
- MAMH-1: Bench clamp motor hanger
- C.TXR-1: Foot pedal
- S-10801TX: Outer sheath
- S-10823: Inner square drive shaft
- MP319P: Motor brushes & caps

FEATURES

- Tool holder: 6.4 mm / 1/4"
- Stroke length: 0-6 mm / 0-.235"
- Motor: 5,000 rpm



All Tool Kits are packed in a sturdy plastic case and come with operating wrenches.

Freedom® Flex Shaft Rotary Handpieces

MODEL H.30 HANDPIECE WITH KEY DRIVE

The Model 30 Handpiece features a 3 jaw chuck with a shank accessory capacity of 0 to 5/32" (4mm).

Supplied with a #72 Chuck Key, the greased sealed ball bearings provide long trouble-free operation.

This handpiece is driven by a flex shaft drive motor with key drive and a TXR foot pedal speed control.



MODEL H.44T HANDPIECE WITH KEY DRIVE

The Model 44 Handpiece accommodates rotary accessories with shank sizes up to 1/4" diameter. It is supplied with three collets (3/32", 1/8" and 1/4"), spindle lock pin and collet wrench. This Handpiece is driven by a flex shaft drive motor with key drive and a TXR foot pedal speed control.

Part No.	Capacity	Range
442	3/32"	.085" to .093"
443	1/8"	.113" to .125"
444	5/32"	.144" to .156"
445	3/16"	.177" to .187"
447	1/4"	.238" to .250"



Diprofil® Micro-Motor Rotary Handpieces

DIPROFIL ROTARY HANDPIECE C-HPM-B1

This micro-motor driven rotary handpiece with carbon brush motor is used together with power unit DPU-3 or the twin power controller Marathon HA-700. It features a quick change design for both the collet and the tool. Supplied with 3.0mm collet; optional 2.35mm collet is available.

TECHNICAL DATA

- Speed Maximum: 38,000 rpm
- Consumed power: 100 W
- Torque: 4.0N cm
- Weight: 285 g
- Vibration: 2.5 m/s²



DIPROFIL® BRUSHLESS ROTARY HANDPIECE C-HPM-BL1

A micro-motor driven high speed rotary handpiece with brushless motor for use with HA-700 Marathon twin controller. It features a quick change design for both the collet and the tool. Supplied with 3.0mm collet; optional 2.35mm collet is available.

TECHNICAL DATA

- Speed Maximum: 40,000 rpm
- Consumed power: 230 W
- Torque: 7.6N cm
- Weight: 350 g
- Noise: < 70 db(A) at 40,000 rpm
- Vibration: 2.5 m/s²



DIPROFIL® BRUSHLESS ROTARY HANDPIECE C-HPM-BL2

A micro-motor driven ultra high speed rotary handpiece with brushless motor for use with HA-700 Marathon twin controller. It features a quick change design for both the collet and the tool. Supplied with 3.0mm collet; optional 2.35mm collet is available.

TECHNICAL DATA

- Speed Maximum: 50,000 rpm
- Consumed power: 230 W
- Torque: 7.6N cm
- Weight: 350 g
- Noise: < 70 db(A) at 50,000 rpm
- Vibration: 2.5 m/s²



Diprofil® Mini-Filing/ Micro-Motor Systems

DIPROMINI TRANSVERSE POLISHING/FILING MACHINE FMV/D

The Dipromini Transverse Polishing/Filing Machine provides left-to-right transverse movement of the head. This tool requires a HPM-B1 brush motor controlled by a DPU-3 power unit or HA-700 Marathon twin power unit.

TECHNICAL DATA

- Tool holder: Max. Ø3.5 mm
- Stroke length: Variable stroke 0-4 mm (measured 60 mm from the machine housing)
- Speed: Max.12,000 rpm at 2 mm stroke length (Recommended 6,000 - 10,000) rpm
- Dimension: Ø24 mm
- Weight: 195 - 240 g
- Noise: <75 dB(A) at 12,000 rpm
- Vibration: <2.5 m/s²



*Frequency weighed hand/ arm vibration, principally in accordance with ISO 28927-8.
For further details, see diagram and other information in the Operation Guide.*

DIPROMINI RECIPROCATING POLISHING/FILING MACHINE FMR/D

The Dipromini Reciprocating Polishing/Filing Machine provides forward-back reciprocating movement of the head. It requires a HPM-B1 brush motor controlled by a DPU-3 power unit or HA-700 Marathon twin power unit. Available with three different stroke lengths:

Stroke Length	Part Number	Vibration
0.5 mm	FMR/D5	< 2.5 m/s ²
1.0 mm	FMR/D10	< 2 - 2.8 m/s ²
1.5 mm	FMR/D15	< 2 - 2.5 m/s ²



TECHNICAL DATA

- Tool holder: Max. Ø3.5 mm
- Stroke length: 0.5, 1.0 or 1.5 mm
- Speed Maximum: 10,000 rpm (Recommended: 5,000 - 8,000 rpm)
- Dimension: Ø24 mm
- Weight: 120 g
- Noise: <70 dB(A) at 7,000 rpm

*Frequency weighed hand/arm vibration, principally in accordance with ISO 28927-8.
For further details, see diagram and other information in the Operation Guide.*

MICRO-MOTOR HPM-B1

The DC Brush Micro-Motor powers the Diprofil Mini Polishing/Filing Machine types FMR/D, FMV/D and rotary handpiece type C-HPM-B1. This motor is controlled by a DPU-3 power unit or HA-700 Marathon twin power unit.

TECHNICAL DATA

- Speed maximum: 38,000 rpm
- Consumed power: Max. 100 W
- Torque: 4.0N cm
- Weight: 190 g
- Dimensions: L100 x Ø29.5 mm
- Noise: <70 db(A) at 38,000 rpm
- Vibration: <2.5 m/s²



BRUSHLESS MICRO-MOTOR HPM-BL1

The Brushless Micro-Motor powers the Di-Pro FXV/D Polishing/Filing Machine. This brushless motor is controlled by a HA-700 Marathon twin power unit.

TECHNICAL DATA

- Speed maximum: 40,000 rpm
- Consumed power: Max. 230 W
- Torque: 8.5N cm
- Weight: 255 g
- Dimensions: L100 x Ø27 mm
- Noise: <70 db(A) at 40,000 rpm
- Vibration: <2.5 m/s²



Power Packs

DIPROFIL® POWER UNIT DPU-3

This compact and ergonomic power unit replaces the DPU/2 and is designed for use together with dedicated rotary handpieces and micro-motor driven reciprocating Diprofil® polishing/filing machines with carbon brush motors. It has high torque and electrical feedback circuitry. Other features include continuously variable speed, forward/reverse switch and automatic overload protection. The DPU-3 is supplied with foot control DPU-3-FC for optional speed adjustment.

TECHNICAL DATA

- Input: AC 110/220 V at 50/60 Hz
- Output: DC 0 - 32 V, 1.2 A
- Power: Max. 100 W
- Weight Power Unit: 1.7 kg
- Dimensions Power Unit: W115 x D147 x H96 mm
- Weight Foot Control: 585 g



For brush-type motors only

HA-700 MARATHON TWIN POWER UNIT

The Marathon Twin Power Unit features the versatility of powering and controlling carbon brush motors as well as brushless micro-motors (not simultaneously). The HA-700 offers hand dial variable speed control with digital display, forward/reverse switch and automatic overload protection.

TECHNICAL DATA

- Input: AC 200 ~ 240 V at 50/60 Hz
- Output: DC 0 - 32 V, 1.6 A
- BLDC 0 - 32 V, 1.6 A
- Power DC: Max. 185 W
- Power BLDC: Max 245 SW
- Weight Power Unit: 2.9 kg
- Dimensions Power Unit: W137 x D232 x H180 mm
- Weight Foot Control: 575 g



For both brush and brushless-type motors

HA-700 MARATHON TWIN POWER UNIT (CONT.)

TECHNICAL DATA

- Supports brush and brushless type motors
- Easy to read digital display showing speed in rpm
- Precise rheostat speed dial control from 1,000 - 50,000 rpm
- Drives tools with high torque at all speeds for unstoppable power
- Error code display function /self diagnosis system

Caution: Be sure to remain within manufacturer's rpm recommendation for tool.

Diprofil® Ultrasonic System

DIPROSONIC DUS-300 ULTRASONIC FINISHING/ POLISHING SYSTEM FROM DIPROFIL®

The main advantage of the Diprosonic DUS-300 Ultrasonic Finishing/Polishing System is its very short stroke length (10 - 35 mm) at a very high frequency (18 - 25 kHz). This makes this unit ideal for working in narrow and confined spaces such as cavities and slots where a short stroke length is preferable. For this kind of delicate work, the Diprosonic will give you precise finishing with rapid stock removal in a relatively clean environment without the need for lubricating fluids, etc.

The unit is excellent for use together with ceramic fiber stones and sintered diamond files, but it is also possible to use electroplated diamond files as long as the shank of the used tool is kept as short as possible.

Operation is either by hand or the included foot switch and the unit will automatically find the right frequency for each tool.

FEATURES & BENEFITS

- 36 W max. output
- Two output levels (high/low)
- Capable of long working periods
- Auto feedback system
- Small, compact and low weight

TECHNICAL DATA

- Control Unit:**
- Input: AC 90 - 220 V, 50/60 Hz
 - Ultrasonic Power Output: 36 W
 - Frequency: 18 - 25 kHz
 - Stroke: 10 - 35 mm
 - Dimensions: 144W x 195D x 95H mm
 - Weight: 658 g
- Handpiece:**
- Cord length: 1500 mm
 - Dimensions: o 30 x 131 mm
 - Weight 185 g

SYSTEM INCLUDES

- Ultrasonic Handpiece for DUS-300 (DUS-300-HP)
- Handpiece Cable (DUS-5)
- Power Cord - US type 110V (DUS-6)
- Foot switch (DUS-300-FS)
- 10/11 mm Spanner (DUS-8)
- 2.5 mm Hex-key (DUS-9)
- Handpiece stand (DUS-10)
- Tool-holder 1.1 mm (DUS-11)
- Tool-holder dia. 3 mm (DUS-30)
- Tool Kit Complete* (DUS-300-TK), consisting of 1 ea.
 - Fiber Stone 4 x 1 x 50 mm, 250 grit
 - Fiber Stone 4 x 1 x 50 mm, 400 grit
 - Fiber Stone 4 x 1 x 50 mm, 700 grit
 - Fiber Stone 6 x 1 x 50 mm, 250 grit
 - Fiber Stone 6 x 1 x 50 mm, 400 grit
 - Fiber Stone 6 x 1 x 50 mm, 700 grit
 - Sintered Diamond File DLU-641, 400 grit
 - Sintered Diamond File DLU-642, 600 grit
 - Sintered Diamond File DLU-740, 200 grit
 - Sintered Diamond File DLU-741, 400 grit

Engis reserves the right to change or substitute standard accessories





DIPROFIL® FILES

Diprofil® Diamond and Steel Files

Diprofil® Diamond Files are made from carefully selected quality diamonds, precisely bonded to obtain the best physical properties for added strength and resistance to wear. Diamond files are excellent for EDM scale removal and for use on carbide, hardened steel, ceramics and other hard materials.

Page	Type	Intended Use
29	DLA	Short machining files for general use. Designed with a semi-flexible shank to obtain a good contact with the work piece. These precision files are the basic type for use with the Diprofil Polishing Machines. Different shapes and grain sizes are available as well as safe-sided types. Medium to high stroke (3-5 mm).
30	DLE	Long precision machine files for general use. Low to medium stroke (2-4 mm). Different shapes and grain sizes are available as well as two safe-sided types. Low to medium stroke (2-4 mm).
30	DLF	Precision riffle type machine files. Especially recommended for use on shaped surfaces. Available in both medium and coarse diamond grains.
31	DLK	Large machine files for use together with the heavy-duty type machines with Ø6.4mm tool holder. Max 4 mm stroke recommended to avoid high levels of vibrations. Different shapes available as well as a safe sided type.
32	DLN	Precision mini hand files for delicate work. Different shapes.
32	DLG	“Habilis” type diamond hand files for general use. This file type can be comfortably used without a fitted handle.
33	DLH	Precision hand files for general use. Different shapes available as well as safe-sided types.
33	DLS	Conical hand files for general use. Specially recommended for EDM scale removal and other preparation of thin slots, e.g. after wire-EDM machining. Different sizes and grain sizes are available.
34	DBH	Hand files for general use.
35	DLL	Short conical hand files for general use. Specially recommended for EDM scale removal and other preparation of thin slots, e.g. after wire-EDM machining. Different sizes and grain sizes are available.
36	DLD	One sided riffle type hand files. Specially recommended for use on shaped surfaces.
37	DLX	Hand files for general use. This file type can be comfortably used without a fitted handle.
38	DLQ	Extra long (200 mm) hand files for general use. Different shapes are available.

Page	Type	Intended Use
39	DLM	Short conical machine files for general use. Specially recommended for EDM scale removal and other preparation of thin slots, e.g. after wire-EDM machining. Different shapes and grain sizes are available
40	DBE	Long machine files for general use. Low to medium stroke (2-4 mm). Different shapes and grain sizes are available.
41	DLB	Riffle type machine files. Especially recommended for use on shaped surfaces.

Diprofil® Precision Steel Files are great for use on soft and semi-hard steel as well as other materials of low and medium hardness.

Page	Type	Intended Use
41	STL-1 – STL-6	Standard steel files for use in Diprofil polishing machines. Low to medium stroke (2-4 mm). Available in both medium (-00) and fine (-1) cut as well as in different shapes.
41	STL-11 – STL-16	Precision riffle type machine files. Especially recommended for use on shaped surfaces. Low to medium stroke (2-4 mm). Available in both medium (-00) and fine (-1) cut as well as in different shapes.
42	STL-21 – STL-26	Mini steel files for use in Diprofil polishing machines. Low to medium stroke (2-4 mm). Available in both medium (-00) and fine (-1) cut as well as in different shapes.
42	STL-101	Medium sized steel files especially recommended for deburring of cast aluminum goods. Low to medium stroke (2-4 mm). Available in both medium (-00) and fine (-1) cut.

Diprofil® Precision Diamond Files

DLA PRECISION FILES FOR DIPROFIL® FILING MACHINES

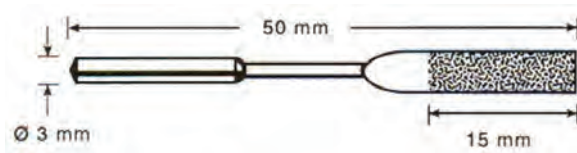

Shape	Size mm	Diamond D64* • 50 (fine)	Diamond D151* • 100 (medium)	Diamond D181* • 150 (coarse)
Standard Files				
	2 x 1	DLA-2x1S	DLA2x1S-D151	DLA2x1S-D181
	3 x 1	DLA-3x1S	DLA3x1S-D151	DLA3x1S-D181
	4 x 1	DLA-4x1S	DLA4x1S-D151	DLA4x1S-D181
	4 x 2	DLA-4x2S	DLA4x2S-D151	DLA4x2S-D181
	5 x 2	DLA-5x2S	DLA5x2S-D151	DLA5x2S-D181
	Ø1	DLA-1	DLA-1	DLA-1
	Ø2	DLA-2	DLA-2	DLA-2
	Ø3	DLA-3	DLA-3	DLA-3
	Ø4	DLA-4	DLA-4	DLA-4
	2 x 2 x 2	DLA-T2S	DLA-T2S	DLA-T2S
	3 x 3 x 3	DLA-T3S	DLA-T3S	DLA-T3S
	4 x 4 x 4		DLA-T4S	DLA-T4S
	r = 1		DLA-R1S	
	r = 1.5		DLA-R1.5S	
	r = 2	DLA-R2S	DLA-R2S	DLA-R2S
	r = 5	DLA-R2.5xR5	DLA-R2.5xR5	DLA-R2.5xR5
	r = 2.5			
Safe-Sided Files				
	2 x 1	DLA-2x1	DLA-2x1	DLA-2x1
	3 x 1	DLA-3x1	DLA-3x1	DLA-3x1
	4 x 1	DLA-4x1	DLA-4x1	DLA-4x1
	4 x 2	DLA-4x2	DLA-4x2	DLA-4x2
	5 x 2	DLA-5x2	DLA-5x2	DLA-5x2
	0.5 x 4		DLA-0.5x4	
	0.75 x 4		DLA-0.75x4	
	1 x 4		DLA-1x4	DLA-1x4
	2 x 2 x 2	DLA-T2	DLA-T2	DLA-T2
	3 x 3 x 3	DLA-T3	DLA-T3	DLA-T3
	4 x 4 x 4		DLA-T4	DLA-T4
	r = 1		DLA-R1	
	r = 1.5		DLA-R1.5	
	r = 2	DLA-R2	DLA-R2	DLA-R2





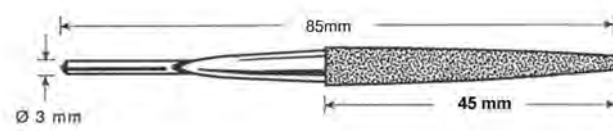

*Grain Sizes according to FEPA

DLE PRECISION FILES FOR DIPROFIL® FILING MACHINES





Shape	Size mm	Diamond D151* • 100 (medium)	Diamond D181* • 150 (coarse)
-------	---------	---------------------------------	---------------------------------

Standard Files

	5 x 1	DLE11-D151	DLE11-D181
	Ø3	DLE2	DLE2-D181
	5 x 2	DLE30-D151	
	5 x 2	DLE4	
	3.5 x 3.5 x 3.5	DLE5	DLE5-D181
	Ø2.5	DLE6	DLE6-D181

Safe-Sided Files



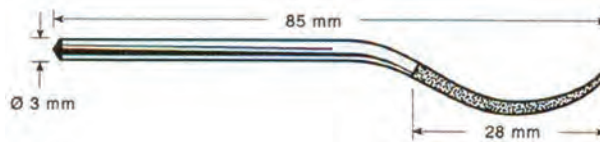

	5 x 1	DLE1	DLE1-D181
	5 x 2	DLE3	

DLF PRECISION FILES FOR DIPROFIL® FILING MACHINES













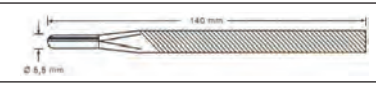

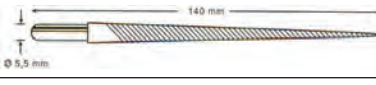
Shape	Size mm	Diamond D151* • 100 (medium)	Diamond D181* • 150 (coarse)
-------	---------	---------------------------------	---------------------------------

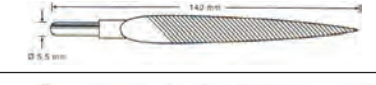
Standard Files

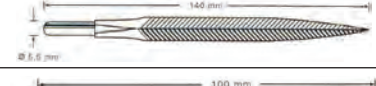
	4.5 x 2.5	DLF-1	DLF-1
	Ø3	DLF-2	DLF-2
	5 x 2.5	DLF-4	DLF-4
	3 x 3	DLF-6	DLF-6

*Grain Sizes according to FEPA

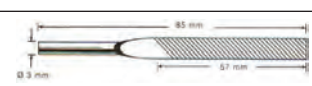
DLK PRECISION FILES FOR DIPROFIL® FILING MACHINES

	Shape	Size mm	Diamond D151* • 100 (medium)
Standard Files			
		10 x 2.5	DLK-11
		Ø6.3	DLK-2
		12.2 x 3.7	DLK-3
		9.6 x 9.6 x 9.6	DLK-5
		∅5.3	DLK-6
Safe-Sided Files			
		10 x 2.5	DLK-1

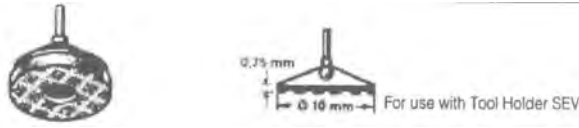
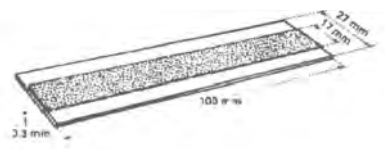
	Diamond D64* • 50 (fine)	Diamond D151* • 100 (medium)	Diamond D181* • 150 (course)
 For use with Tool Holder FBA-2	DLC-7x18	DLC-7x18	DLC-7x18
 For use with Tool Holder SEV	DLC-7x18	DLD-10	DLD-10
		DTA	

*Grain Sizes according to FEPA

Diprofil® Precision Hand Files

DLN PRECISION FILES FOR DIPROFIL® FILING MACHINES











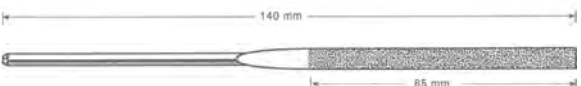



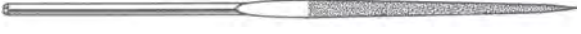





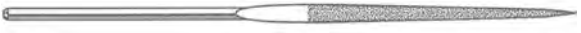



	Shape	Size mm	Diamond D151* • 100 (medium)
		4 x 1.3	DLN-1
		Ø1.6	DLN-2
		4 x 1.8	DLN-3
		4 x 1.6	DLN-4
		3 x 3 x 3	DLN-5
		Ø1.9	DLN-6
		4.1 x 1.5	DLN-7
Shaft diameter 3mm	File set containing 7 files, one each of DLN1 to DLN-7.		DLN-100

DLG PRECISION FILES FOR DIPROFIL® FILING MACHINES





	Shape	Size mm	Diamond D151* • 100 (medium)
		10.3	DLG-1
		Ø6.5	DLG-2
		12 x 4	DLG-3
		9.5 x 9.5 x 9.5	DLG-4
		Ø5.5	DLG-5
Shaft diameter 6mm	File set containing 5 files, one each of DL-1 to DLN-5.		DLG-100

*Grain Sizes according to FEPA

DLH PRECISION HAND FILES

	Shape	Size mm	Diamond D151* • 100 (medium)
		5.3 x 1.4	DLH-11
		∅3	DLH-2
		5.1 x 2.2	DLH-4
		3.8 x 3.8 x 3.8	DLH-5
		∅2.6	DLH-6
		5.2 x 1.6	DLH-8
		5.0 x 1.6	DLH-9
		5.0 x 2.4	DLH-10
		5.6 x 1.9	DLH-30
Safe-Sided Files			
		4.8 x 1.1	DLH-1
		5.5 x 1.7	DLH-3
		4.9x2.1	DLH-7
		File set containing 7 diamond files, one each of DLH-1 through DLH-7	DLH/100
		File set containing 7 diamond files, DLH-2, DLH-5, DLH-6, DLH-8, DLH11 and DLH-30	DLH/100S

DLS DIPRO CONICAL DIAMOND HAND FILES

Shape	Size mm	Item Number Diamond D46	Item Number Diamond D76	Item Number Diamond D107
	4 x 2		DLS-1-D76	
	4 x 3	DLS-2-D46	DLS-2-D76	DLS-2-D107
	6 x 6	DLS-3-D46	DLS-3-D76	DLS-3-D107
	8 x 8	DLS-4-D46	DLS-4-D76	DLS-4-D107

*Grain Sizes according to FEPA

DLS DIPRO CONICAL DIAMOND HAND FILES (CONT.)

Diamond Files For Diprofil® Filing Machines

DLS Set: Set consisting of the above 10 different DLS hand files

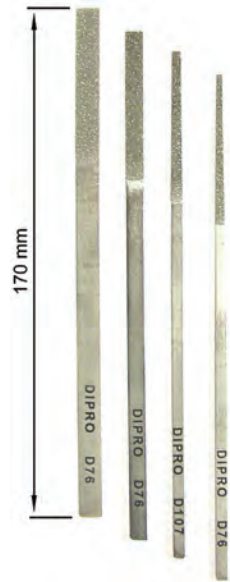

Total file length 170 mm



Item Number: DLS/1

DBH DIPRO DIAMOND HAND FILES

Shape	Size mm	Fine	Medium	Coarse
		Item Number Diamond D46	Item Number Diamond D76	
	6 x 1.5	DBH-1-D46	DBH-1-D76	DBH-1-D126
	Ø3	DBH-2-D46	DBH-2-D76	DBH-2-D126
	5 x 2	DBH-3-D46	DBH-3-D76	DBH-3-D126
	5 x 2	DBH-4-D46	DBH-4-D76	DBH-4-D126
	3.5	DBH-5-D46	DBH-5-D76	DBH-5-D126
	2.5 x 2.5	DBH-6-D46	DBH-6-D76	DBH-6-D126
	6 x 2	DBH-7-D46	DBH-7-D76	DBH-7-D126
	5.4 x 1.5	DBH-8-D46	DBH-8-D76	DBH-8-D126
	1.7 x 6	DBH-9-D46	DBH-9-D76	DBH-9-D126
	6 x 1.5	DBH-10-D46	DBH-10-D76	DBH-10-D126

*Grain Sizes according to FEPA

DBH DIPRO DIAMOND HAND FILES (CONT.)

Diamond Files For Hand Filing



Total file length approx 140mm
Shaft diameter 3mm

DBH Set: Set consisting of the above 10 different DBH hand files



Item Numbers: DBH-SET-D46, DBH-SET-D76,
DBH-SET-D126

DLL DIPRO CONICAL DIAMOND HAND FILES

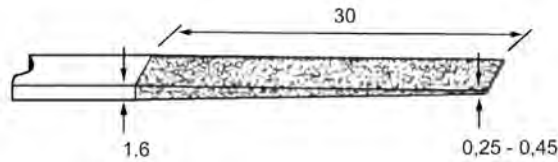

Shape	Size mm	Item Number Diamond D30	Item Number Diamond D46	Item Number Diamond D76
	1.7 x 2	DLL-1-D30	DLL-1-D46	DLL-1-D76
	1.7 x 4	DLL-2-D30	DLL-2-D46	DLL-2-D76
	1.7 x 6	DLL-3-D30	DLL-3-D46	DLL-3-D76
	5 x 2	DLL-4-D30		

*Grain Sizes according to FEPA

DLL DIPRO CONICAL DIAMOND HAND FILES (CONT.)

Diamond Files For Hand Filing

DLL Set: Set consisting of the above 10 different DLL hand files



Total file length approx 140mm
Shaft diameter 3mm

Item Number: DLL-SET

DLD DIPRO DIAMOND HAND FILES

Diamond Files For Hand Filing – Technical Specifications

	DLD-1	DLD-2	DLD-3	DLD-4	DLD-5
Item Number Diamond D107	DLD-1-D107	DLD-2-D107	DLD-3-D107	DLD-4-D107	DLD-5-D107
	DLD-6	DLD-7	DLD-8	DLD-9	DLD-10
Item Number Diamond D107	DLD-6-D107	DLD-7-D107	DLD-8-D107	DLD-9-D107	DLD-10-D107

DLD DIPRO DIAMOND HAND FILES (CONT.)

Diamond Files For Hand Filing



Total file length approx 140mm
Shaft diameter 3mm











DLD Set: Set consisting of the above 10 different DLD hand files



Item Number: DLD-SET-D107

DLX DIPRO DIAMOND HAND FILES SHAPE

Total file length approx 200mm





	Shape	Size mm	Item Number Diamond D151
		11 X 3.5	DLX-1-D151
		Ø5	DLX-2-D151
		10.5 X 4.4	DLX-3-D151
		7.7	DLX-4-D151
		Ø6.3	DLX-5-D151

DLX Set: Set consisting of the above 5 different DLX hand files. Item Number: DLX-SET-D151



*Grain Sizes according to FEPA

DLQ DIPRO DIAMOND HAND FILES

Shape	Size mm	Item Number Diamond D126
	8.5 X 1.6	DLQ-1-D126
	∅4	DLQ-2-D126
	7 x 2.5	DLQ-3-D126
	∅3.5	DLQ-4-D126
	4.5	DLQ-5-D126

Diamond Files For Hand Filing



Total file length approx 200mm
Shaft diameter 4mm

DLQ Set: Set consisting of the above 5 different DLQ hand files







Item Number: DLQ-SET-D126

**Grain Sizes according to FEPA*

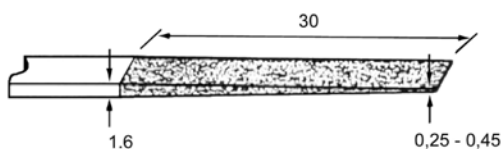
Diprofil® Precision Machine Files

DLM DIPRO CONICAL DIAMOND MACHINE FILES



Shape	Size mm	Item Number Diamond D46	Item Number Diamond D107
	2.5 x 1.6	DLM-1-D46	DLM-1-D107
	4 x 1.6	DLM-2-D46	DLM-2-D107
	6 x 1.6	DLM-3-D46	DLM-3-D107

Diprofil® Conical Diamond Files For Diprofil® Filing Machines

DLM Set: Set consisting of the 6 different DLM files (as specified above)

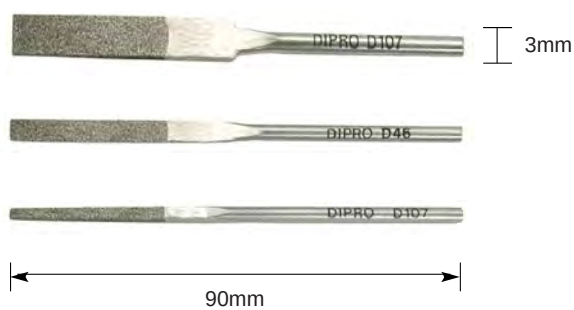

Max file length 90mm
Max shaft diameter 3mm



Item Number: DLM/1

*Grain Sizes according to FEPA

DBE DIPRO DIAMOND MACHINE FILES

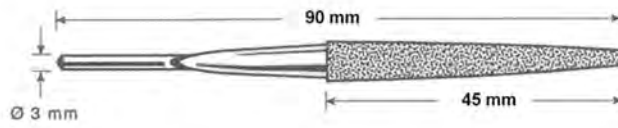

Shape	Size mm	Fine	Medium	Coarse
		Item Number Diamond D46	Item Number Diamond D76	Item Number Diamond D107
	4 x 2	DBE-1-D46	DBE-1-D76	DBE-1-D107
	Ø3	DBE-2-D46	DBE-2-D76	DBE-2-D107
	5 x 2	DBE-3-D46	DBE-3-D76	DBE-3-D107
	5 x 2	DBE-4-D46	DBE-4-D76	DBE-4-D107
	3.5	DBE-5-D46	DBE-5-D76	DBE-5-D107
	2.5 x 2.5	DBE-6-D46	DBE-6-D76	DBE-6-D107

Diamond Files For Diprofil® Filing Machines

DBE Set: Set consisting of the above 6 different DBE machine files



Total File Length Approx 90mm

Item Numbers: DBE-SET-D46, DBE-SET-D76 DBE-SET-D107

*Grain Sizes according to FEPA

DLB DIPRO DIAMOND MACHINE FILES

Approx file length 65 mm. Shaft diameter 3 mm.

	Shape	Size mm	Item Number Diamond D107
		3.2 X 1.4	DLB-1-D107
		Ø3	DLB-2-D107
		Ø3	DLB-3-D107
		2.5	DLB-4-D107
		3.2 x 1.4	DLB-5-D107
		4 x 2	DLB-6-D107

DLB Set: Set consisting of the above 6 different DLB machine files. Item Number: DLB-SET-D107

Diprofil® Precision Steel Files

Steel Files are for use on soft and semi-hardened steel as well as other materials of low and medium hardness.

STL 1 - STL 26 PRECISION STEEL FILES

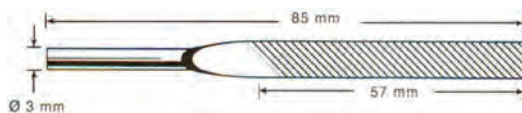

Shape	Size mm	Coarse Cut -00	Fine Cut -1
	5 x 1.5	STL1.00	STL1.1
	Ø3	STL2.00	STL2.1
	5 x 2	STL3.00	STL3.1
	5 x 2	STL4.00	STL4.1
	3.5 x 3.5 x 3.5	STL5.00	STL5.1
	∅2.5	STL6.00	STL6.1
Set consisting of one each of STL-1 to STL-6		STL.1/6.00	STL.1/6.1

*Grain Sizes according to FEPA

STL 1 - STL 26 PRECISION STEEL FILES (CONT.) AND STL 101 PRECISION STEEL FILES

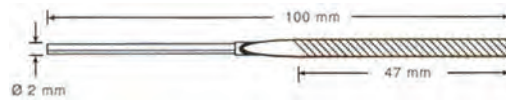

Shape	Size mm	Coarse Cut -00	Fine Cut -1
	3.3 x 1	STL21.00	STL21.1
	Ø2	STL22.00	STL22.1
	3.2 x 1.1	STL23.00	STL23.1
	3 x 1.3	STL24.00	STL24.1
	2.2 x 2.2 x 2.2	STL25.00	STL25.1
	Ø1.7	STL26.00	STL26.1
Set consisting of one each of STL-1 to STL-6		STL.21/26.00	STL.21/26.1



Shape	Size mm	Coarse Cut -00	Fine Cut -1
	4 x 2	STL11.00	STL11.1
	Ø3	STL12.00	STL12.1
	4.7 x 2.5	STL13.00	STL13.1
	Ø3	STL14.00	STL14.1
Set consisting of one each of STL-1 to STL-6		STL.11/16.00	STL.11/16.1

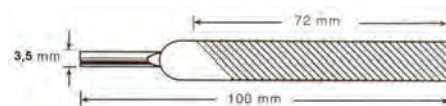

Shape	Size mm	Coarse Cut -00	Fine Cut -1
	10 x 2.5	STL101.00	STL101.1
		STL1A.00	STL1A.1



MINIMO® FINISHING SYSTEMS

Diamond Compounds
Polishing Lubricants
High-Intensity Polish

Diprofil® Finishing Systems
Tools
Accessories

Diprofil® Files

Minimo® Finishing Systems
Tools
Accessories

Rotary Finishing Tools

Finishing Sticks
Stones
Accessories

Welding Units
Accessories

Minimo® One Series

THE MINIMO® ONE

The Minimo® One Series hand finishing system is designed to provide unsurpassed accuracy, reliability, power and versatility, while being comfortable and natural to use with minimum fatigue. An innovative hand switch, built right into the handpiece itself, is just one of many new features that makes Minimo® the most advanced and easy to use handpiece on the market.

Plus, when you use the Minimo® One system in conjunction with DiaMold® diamond compounds, lubricants and the full range of toolroom products from Engis®, you can be assured of high precision results, time and time again (Section 1 of this catalog contains a full description of our diamond compounds and lubricants.)

A - Collets can be changed easily using a V wrench.

B - Minimo® rotary heads utilize a simple tool changing mechanism that does not require wrenches or keys. Tools can be easily changed out by a quick turn of the collet release ring. This facilitates the use of polishing tools with different shank diameters by simply switching out the collets.

C - The Minimo® polishing system offers maximum flexibility with a wide range of both heads and motor assemblies. By optimizing the head and motor assembly combination for each application, you have the perfect tool for every job. The head can be mounted to a motor in a snap.

D - In addition to the On/Off switch on the power supply, each motor is supplied with its own On/Off switch. This allows the operator to stop and start the handpiece quickly, even when working out of reach of the power supply. The switch is inset in the tool to minimize the risk of accidentally starting the motor.

E - Removable Curled Power Cord



EASY EXCHANGE OF COLLETS (A)



EASY EXCHANGE OF TOOLS (B)



VERSATILITY OF HANDPIECES (C)



HAND SWITCH FOR MAXIMUM CONTROL (D)



Motor Model & Maximum Speed (x 1,000)

Minimo® One

THE MINIMO® ONE HANDPIECES & HEAD ATTACHMENTS

Adding to the Minimo® One's versatility is a complete array of attachments, including heads, clamp heads and gear reduction units for more power.

Versatility of Handpieces: Minimo® One Rotary Handpieces consist of a combination of various heads and motor assemblies of different specifications. Different combinations of heads, motor assemblies and other attachments can customize the tool for different applications. Heads can be mounted to motors in a snap.

Variety of Handpieces: Engis® offers a full selection of handpieces, ranging from Standard, Slender and Heavy Duty Rotary units to POLYTOR Ultrasonic systems – the ideal solution for removing EDM scale.



Polytor Ultrasonic Handpiece



Standard Rotary Straight Head Handpiece



Rubron Lateral Swing Handpiece



Anglon Angle Head Handpiece



Mini-Belt Sander



Recipron Reciprocating Handpiece

MINIMO® ONE SERIES - TABLE OF CONTENTS

Product	Page
Power Packs	45
Polytor Ultrasonic Systems	46
Standard Rotary Handpieces	47
Slender Rotary Handpieces	50
Heavy Duty Rotary Handpieces	51
Rubron System	54
Anglon Systems & Tools	55
Recipron	63
Mini-Belt Sander	64
Motors	66
Heads	67
Accessories	70

Minimo® Power Packs

C2112 DC Power Pack (Replaces C311 & C111)

2 Standard Handpiece Stations
60 VA
Input Voltage: C115V ± 5% (50/60 Hz)
Output Voltage: DC 1-30 V AC
144mm (W) x 218mm (D) x 116mm (H)
5.5 lbs (2.5kg)



P30 Polytor Power Pack (Replaces P211 and P111)

1 Ultrasonic Handpiece Station
30 VA
Input Voltage: AC100~AC240V (50/60Hz)
Output Voltage: See Below
144mm (W) X 221mm (D) X 116mm (H)
Approx. 1.3kg



Features:

- This high-end power pack includes new functions for maximizing the performance of Minitor handpieces.
- The C2112 power pack identifies the type of handpieces which are connected indicates rotation speed and controls optimum torque.
- Also compatible with the earlier handpieces which do not have the motor identification chip.
- Convenient digital display of output rate (%).
- Includes RM11 Rubber Cradle, CA11 Power Cord, and PFU-2.0A Fuse

Features:

- The P30 is equipped with a feedback feature to detect overloading.
- Features an audible beep that lets you know when the handpiece is turned ON/OFF or when the tool is overloaded. This feature allows the handpiece to perform to its full capability without damaging itself or the power pack.
- Output Voltage: 27W max. (STROKE CONTROL, Power Mode on), 18W max. (STROKE CONTROL, Power Mode off), and 18W max. (VOLTAGE CONTROL)
- Includes RM11 Rubber Cradle.
- CA11(115V) power cord and US21 Ultrasonic handpiece are sold separately.

PRODUCT DETAILS

- **Handpiece identification function:** When the Ver. 2 handpiece is connected, the power pack identifies its motor type, indicates its rotation speed and controls optimum torque.
- **Digital display:** Identifies a connected handpiece type, the power pack automatically selects its display type (rotation speed (x1000 min) or output rate (rate %)).
- **Error code display function:** Errors of power pack or handpiece are indicated as error code on the display
- **Microcomputer control:** The high-end microcomputer control identifies the connected handpiece type and manages its optimum output
- **Rotation direction switch:** Allows the user to change the rotation direction of handpiece (forward or reverse).
- **LED load meter:** Loaded condition in operation is displayed on LED meter. Error is alerted by LED meter and sound when overloading.
- **External I/O signal control function is standard:** Input/output signals are available from the foot switch socket located on the back of the power pack.
- **Foot switch holding function (when using V301 foot switch):** Rotation speed set by the variable foot switch can be maintained by pressing the hand switch.
- **NEW BRAKING SYSTEM:** Quick braking system stops the handpiece immediately. In addition, the system can quickly change rotation speed shifting from high to low speed.

Minimo® Polytor Ultrasonic

US21 POLYTOR (ULTRASONIC)

The POLYTOR handpiece (US21) is indispensable for mold finishing, providing powerful and stable ultrasonic vibration.

The US21 is great for small and intricate work especially in slots and ribs where hand work is difficult. Because the reciprocation is short and moves with ultrasonic speed, the tool tip can be used in corners, wall ends and for fine detail work.

Since the frequency is adjusted automatically, operation of the US21 is simple and easy. Because of the tool's aggressive cutting action, processing time is reduced dramatically, saving 70 to 75% of finishing time while improving quality. A large variety of tools for use with the US21 are available for cleaning up milled and EDM surfaces to mirror polishes.

POLYTOR HANDPIECE US21



FEATURES & BENEFITS

- Removing EDM scale
- Convenient for pattern cutting of printed circuit boards
- Ideal for deburring, grinding, cutting, polishing and honing
- Finishing precious metals and jewels

The Hand Switch enables the tool to be switched ON/OFF on the handpiece side as well; this offers maximum convenience when work requires frequent switching ON/OFF or when working out of reach of the Power Pack. This adoption of the new mechanism improves the switch durability as well.

FEATURES & BENEFITS

- Compact and lightweight
- Built-in ON/OFF SWITCH
- Removable curled power cord makes storage convenient
- Employs an advanced high performance oscillating unit
- Compatible with P30 Power Pack

STANDARD TOOLS (1PC EACH)

- SA8103 Holder with SA4102 Diamond File
- SA8151 Holder with SA5005 Ceramic Stone

Toolholder Selection for Polytor Ultrasonic







SA8101	d = Ø1mm	
SA8102	d = Ø2mm	
SA8103	d = Ø3mm	
SA8104	d = Ø4mm	
SA8151	t = 1mm	
SA8152	t = 2mm	
SA8153	t = 3mm	
SA8154	t = 4mm	
SA8181	t = 0.5mm	
SA8182	t = 1mm	

Minimo® Standard Rotary Handpieces

STANDARD ROTARY HANDPIECES

The Minimo® One Handpieces are designed to provide the user with unsurpassed versatility with its quick-change H011/E Standard Head options. Minimo heads and motors have matching threads which make changing a straight tool to a 90 degree tool a very simple process. Tool change is a 1/4 turn process without the need of a special wrench or spanners.

Each motor has an On/Off switch on its side for one-hand operation. 3/32" and 1/8" collets are standard with each handpiece. Seven other collets sizes are available and sold separately.

V112H		2,000 - 50,000 RPM
V212H		2,000 - 40,000 RPM
M112H		1,000 - 35,000 RPM
M212H		1,000 - 30,000 RPM
V212		1,000 - 25,000 RPM
M112		2,000 - 20,000 RPM
M212		1,000 - 15,000 RPM
M112G		660 - 6,600 RPM

Minimo® One Handpieces are used with C2112 Power Pack

STANDARD ROTARY SPECIFICATIONS

	V112H	M212H	M112H	V212H
Speed	Ultra-high speed	High speed	High speed	High speed
Motor Model	KV112H	KM21H	KM112H	KV212H
Head Model	H011/E	H011/E	H011/E	H011/E
Hand Switch Color	Ivory	Red	Violet	Pink
Speed Range RPM	2,000–50,000	3,000–30,000	3,500–35,000	2,000–40,000
Input Voltage (D.C.V.)	3–30	3–30	3–30	3–30
No-load Current (D.C.A.)	0.45	0.40	0.35	0.40
Maximum Torque (cN.M)	2.3	2.8	3.4	2.7
Weight (g) [not including cord]	204	290	232	240
Dimensions (mm)				
L	147	167	160	149
L1	76	96	89	78
L2	71	71	71	71
D	Ø29	Ø33	Ø29	Ø33
D1	Ø26.4	Ø30.4	Ø26.4	Ø30.4
D2	Ø14.5	Ø14.5	Ø14.5	Ø14.5

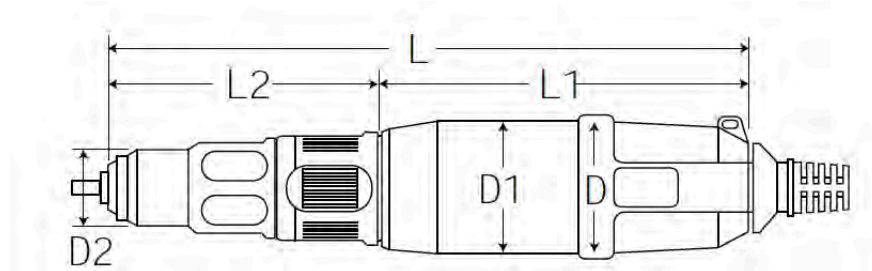

STANDARD ROTARY SPECIFICATIONS (CONT.)

	M212	M112	V212H	M112G
Speed	Medium speed	Medium speed	Medium speed	Geared low speed
Motor Model	KM21	KM11	KV21	KM11G
Head Model	H011/E	H011/E	H011/E	H011/E
Hand Switch Color	Green	Blue	Orange	Yellow
Speed Range RPM	1,500–15,000	2,000–20,000	2,500–25,000	660–6,600
Input Voltage (D.C.V.)	3–30	3–30	3–30	3–30
No-load Current (D.C.A.)	0.30	0.30	0.40	0.34
Maximum Torque (cN.M)	5.9	4.5	3.9	9.8
Weight (g) [not including cord]	290	232	240	273
Dimensions (mm)				
L	167	160	149	176
L1	96	89	78	105
L2	71	71	71	71
D	Ø33	Ø29	Ø33	Ø29
D1	Ø30.4	Ø26.4	Ø30.4	Ø26.4
D2	Ø14.5	Ø14.5	Ø14.5	Ø14.5

COLLET SELECTION TABLE (STANDARD ROTARY)



Code	KP-050 (mm)	KP-051 (mm)	KP-007 (mm)	KP-005 (mm)	KP-052 (mm)	KP-031 (mm)	KP-036 (mm)	KP-032 (mm)	KP-033 (mm)
Inside Diameter (mm)	Ø1.0	Ø1.2	Ø1.4	Ø1.6	Ø1.8	Ø2.0	Ø2.34 (3/32")	Ø3.0	Ø3.175 (1/8")

Minimo® Slender Rotary Handpieces

SLENDER ROTARY HANDPIECES

These are small and lightweight handpieces with precision balanced motors for vibration-free operation – very comfortable to hold and use for very long periods of time.

3/32" and 1/8" collets are standard with each handpiece. Seven other collets size are available and sold separately.

V112HS		2,000 - 50,000 RPM
M112HS		1,000 - 35,000 RPM
M112S		1,000 - 20,000 RPM

SLENDER ROTARY SPECIFICATIONS

	V112HS	M112HS	M112S
Speed	Ultra-high speed	High speed	Medium speed
Motor Model	KV11H	KM21H	KV11
Head Model	H021/E	H021/E	H021/E
Hand Switch Color	Ivory	Pink	Blue
Input Voltage (D.C.V.)	3–30	3–30	3–30
No-load Current (D.C.A.)	0.45	0.40	0.30
Maximum Torque (cN.M)	2.3	2.7	4.5
Weight (g) [not including cord]	192	228	222

STANDARD ROTARY SPECIFICATIONS (CONT.)

Dimensions (mm)				
L	145	158	147	158
L1	76	89	78	89
L2	69	69	69	69
D	Ø29	Ø29	Ø33	Ø29
D1	Ø26.4	Ø26.4	Ø30.4	Ø26.4
D2	Ø10.8	Ø10.8	Ø10.8	Ø10.8

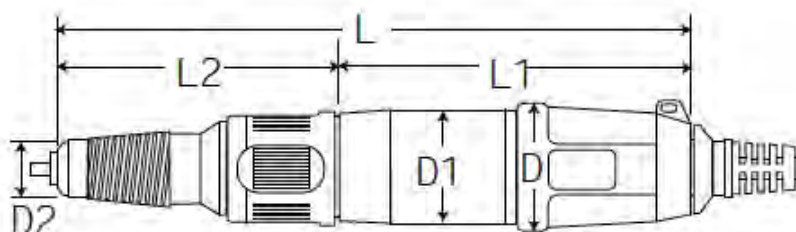

Minimo® Heavy-Duty Rotary Handpieces

HEAVY DUTY HANDPIECES

The Minimo® Heavy Duty Handpiece Series is designed with a reinforced housing. It accepts shank sizes up to 6.35mm for heavy cuts and provides unsurpassed versatility with its quick-change head options. Minimo® heads and motors have matching threads which makes changing a straight tool to a 90 degree tool a very simple process without the need of a special wrench or spanners. Each motor has an on/off switch on its side for one-hand operation.

M212HD HIGH SPEED HANDPIECE

Offers a robust reinforced head housing for added strength and easy grip. Accepts larger shank diameter tooling up to 1/4" diameter. Head is easily removed from its screw mount and replaced with other optional heads. Used with C2112 Power Pack.

TECHNICAL DATA

- Standard Rotary
- Standard Collets: 1/8" & 1/4"
- Speed Range: 3,000-30,000 RPM



Head: H031/E
Motor: KM 21H/ 3,000-30,000 RPM

M212D MEDIUM SPEED HANDPIECE

The lower RPM of this tool offers a higher torque load ratio than the faster RPM model shown on previous page. Can be used with all listed power packs.

TECHNICAL DATA

- **Standard Rotary**
- **Standard Collets: 1/8" & 1/4"**
- **Speed Range: 1,500-15,000 RPM**



Head: H031/E
Motor: KM 21/1,500-15,000 RPM

HEAVY DUTY ROTARY SPECIFICATIONS

	M212HD	M212D
Speed	High speed	Medium speed
Motor Model	KM212H	KM212
Head Model	H031/E	H031/E
Hand Switch Color	Red	Green
Speed Range RPM	3,000–30,000	1,500–15,000
Input Voltage (D.C.V.)	3–30	3–30
No-load Current (D.C.A.)	0.40	0.30
Maximum Torque (cN.M)	4.2	5.9
Weight (g) [not including cord]	350	351
Dimensions (mm)		
L	177	177
L1	96	96
L2	81	81
D	Ø33	Ø33
D1	Ø30.4	Ø30.4
D2	Ø20	Ø20

HEAVY DUTY ROTARY SPECIFICATIONS (CONT.)

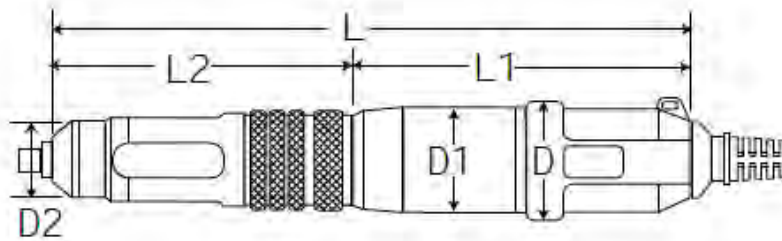

SPEED/ TORQUE CURVE (DATA FOR DIFFERENT MOTOR MODELS)

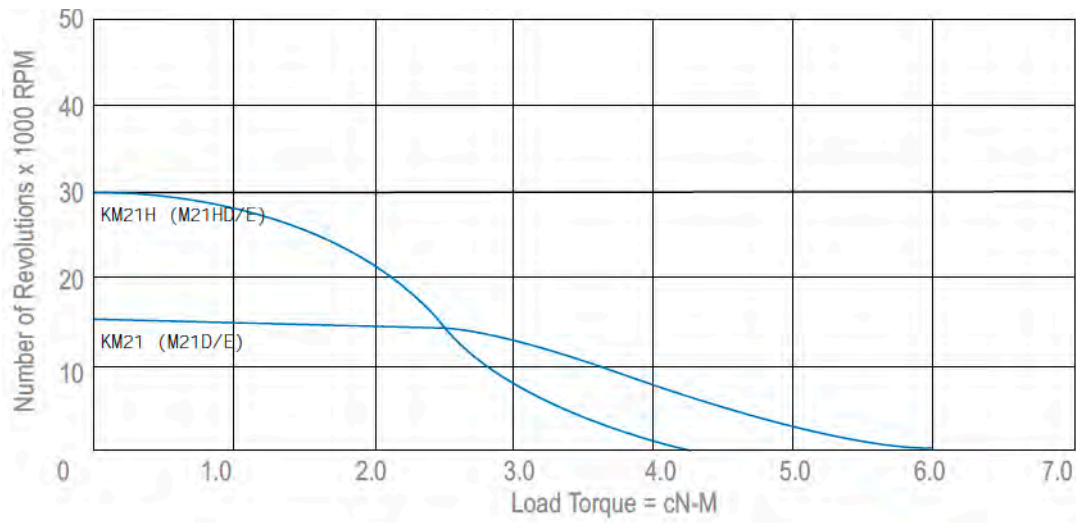

COLLECT SELECTION TABLE (HEAVY DUTY ROTARY)



Code	KP-061 (mm)	KP-062 (mm)	KP-063 (mm)	KP-066 (mm)	KP-067 (mm)	KP-060 (mm)	KP-064 (mm)
Inside Diameter (mm)	Ø2.34 (3/32")	Ø3.0	Ø3.175 (1/8")	Ø4.0	Ø5.0	Ø6.0	Ø6.35 (1/4")

Minimo® Rubron System

M212LRV RUBRON SYSTEM

The Rubron is a unique handpiece with lateral (side-to-side) movement adjustable up to 1.6mm, ideal for finishing narrow slots and grooves, plus deep recesses where precise control is needed.

The Rubron has a tapered toolholder nose to aid in getting into those hard-to-reach areas.

The V-shaped tool holder chuck mounts shank sizes from 1.5 to 4.7mm shafts.

The motor has a built-in ON/OFF switch for easy one-hand operation and is powered by the C2112 Power Pack.



Head: H311
Motor: KM21L/800-8,000 RPM

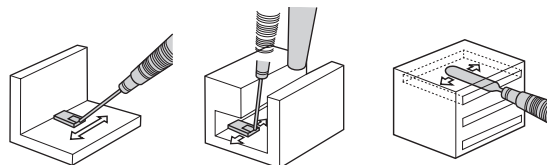

Examples of applications

RUBRON SPECIFICATIONS

	M212LRV
Frequency (times/min)	800 – 8,000
Head Amplitude (mm)	0–1.6
Tool Shank Diameters (mm)	1.5–4.7
Input Voltage (D.C.V.)	3–30
No-load Current (D.C.A.)	0.25
Maximum Torque (cN-M)	6.9
Hand Switch Color	Black
Weight (g)	300

SPEED/ TORQUE CURVE

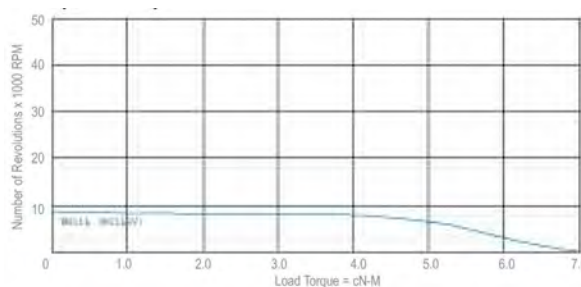

Note: The amplitude depends on the length of the tool used.

Minimo® Anglon Systems

ANGLON SYSTEM

Anglon tools are offered with heavy duty 90° or 120° angled head designs suitable for grinding and polishing of both flat and curved surfaces, especially on those hard-to-reach internal surfaces.

Each tool features a built-in ON/OFF switch, two standard collets (3/32" & 1/8") and a quick and easy tool changing mechanism - no wrenches are required!

Anglon tools offer quick and easy tool exchange - simply turn the collet release ring to lock or remove the tool.



M112GRAD LOW SPEED TOOL WITH 90° ANGLE HEAD

TECHNICAL DATA

- Standard Collets: 1/8" & 3/32"
- Speed Range: 620 - 6,200 RPM
- High torque
- Used with C2112 Power Pack



Head: H221/E
Motor: KM11G

M212RAD MEDIUM SPEED TOOL WITH 90° ANGLE HEAD

TECHNICAL DATA

- Standard Collets: 1/8" & 3/32"
- Speed Range: 1,420 - 14,200 RPM
- Used with C2112 Power Pack



Head: H221/E
Motor: KM11G

M112GA LOW SPEED TOOL WITH 120° ANGLE HEAD

TECHNICAL DATA

- Standard Collets: 1/8" & 3/32"
- Speed Range: 630 - 6,300 RPM
- High torque
- Used with C2112 Power Pack



Head: H231/E
Motor: KM11G

M212A MEDIUM SPEED TOOL WITH 120° ANGLE HEAD

TECHNICAL DATA

- Standard Collets: 1/8" & 3/32"
- Speed Range: 1,440 - 14,400 RPM
- Used with C2112 Power Pack



Head: Head: H231/E
Motor: KM21

ANGLON SPECIFICATIONS

	M112GRAD	M212RAD	M112GA	M212A
Speed	Low speed high torque	Medium speed	Low speed high torque	Medium speed
Motor Model	KM11G	KM21	KM11G	KM21
Head Model	H221/E	H221/E	H231/E	H231/E
Hand Switch Color	Yellow	Green	Yellow	Green
Speed Range RPM	620–6,200	1,420–14,200	630–6,300	1,440–14,400
Input Voltage (D.C.V.)	3–30	3–30	3–30	3–30
No-load Current (D.C.A.)	0.35	.40	0.35	0.40
Maximum Torque (cN.M)	9.8	5.9	9.8	5.9
Weight (g) [not including cord]	368	387	351	395
Dimensions (mm)				
L	167	158	183	174
L1	105	96	105	96
L2	62	62	78	78
D	Ø29	Ø33	Ø29	Ø33
D1	Ø26.4	Ø30.4	Ø26.4	Ø30.4
H	47.5	47.5	47.5	47.5

ANGLON SPECIFICATIONS (CONT.)

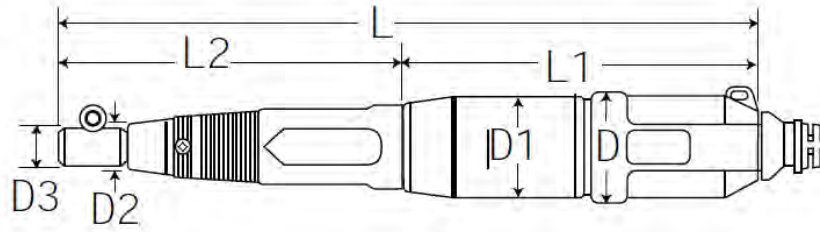

COLLET SELECTION TABLE (ANGLON TOOLS)



Code	KP-050 (mm)	KP-051 (mm)	KP-007 (mm)	KP-005 (mm)	KP-052 (mm)	KP-031 (mm)	KP-036 (mm)	KP-032 (mm)	KP-033 (mm)
Inside Diameter (mm)	Ø1.0	Ø1.2	Ø1.4	Ø1.6	Ø1.8	Ø2.0	Ø2.34 (3/32")	Ø3.0	Ø3.175 (1/8")

SPEED/TORQUE CURVE (DATA FOR DIFFERENT MOTOR MODELS)

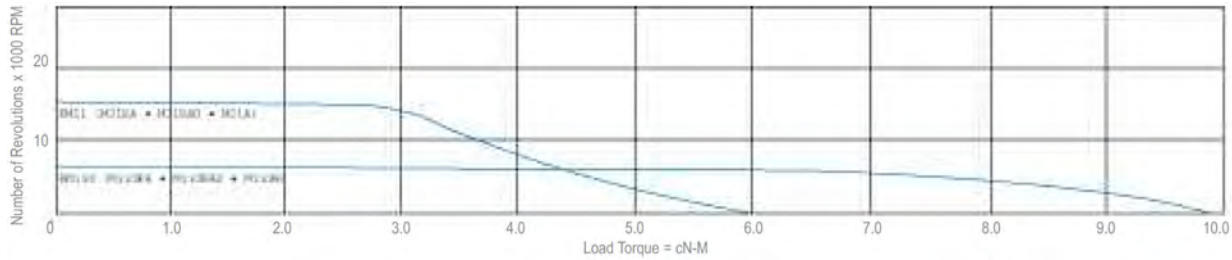

TOOLS FOR ANGLE ROTARY HANDPIECES (5 PER BOX)

Soft rubber pads are available in 4 different diameters (Ø10 mm, Ø20 mm, Ø30 mm and Ø40 mm).

Pressure sensitive adhesive (PSA) backing enables you to replace discs in a snap. The backing also serves as a cushion to enable softer contact with work pieces.

Sandpaper discs resist spalling and loading with aggressive cutting action.

Zirconia discs utilize tough zirconia alumina abrasives developed especially for hard-to-cut materials.



ABRASIVE DISC & POLISHING DISC HOLDERS (20 PER BOX)

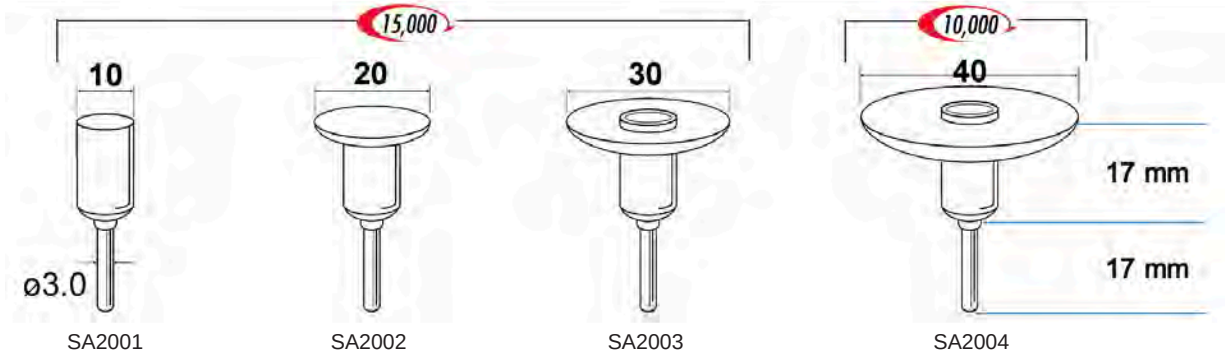

Shank = Ø3.0mm (All Holders)

SOFT RUBBER PADS (20 PER BOX)

These rubber pads mount to the disc holder with PSA backing. The disc face has a Velcro-type surface used to mount the PSA-backed disc above (SA3001, SA3002, SA3003).

Eye protection recommended.

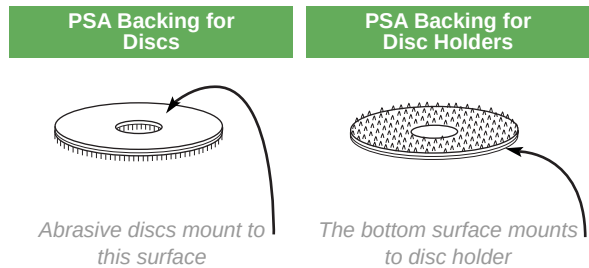

Ø21	SA3001	Ø21	SA3011
Ø31	SA3002	Ø31	SA3012
Ø40	SA3003	Ø40	SA3003

SANDPAPER DISC WITH PSA BACKING (100 PER BOX)

These flexible discs are made of aluminum oxide resin bonded for great durability. The pressure sensitive adhesive (PSA) backing can withstand the heat generated by high friction. PSA discs will hold until removed by hand. There is a peel-off backing on each disc to maintain adhesive freshness.

Eye protection recommended

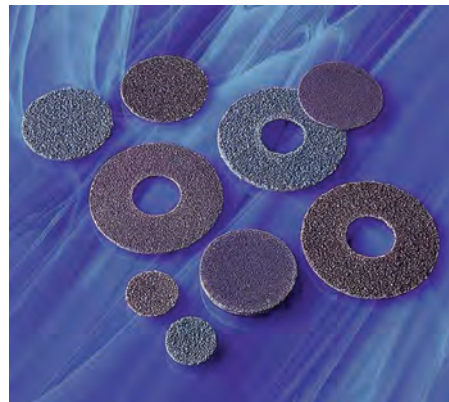

SANDPAPER DISC WITH PSA BACKING (100 PER BOX) (CONT.)

Grit Size	12,000		10,000	
	11	21	31 11	40 11
#60	SA2111	SA2131	SA2151	SA2171
#80	SA2112	SA2132	SA2152	SA2172
#120	SA2113	SA2133	SA2153	SA2173
#180	SA2114	SA2134	SA2154	SA2174
#240	SA2115	SA2135	SA2155	SA2175
#320	SA2116	SA2136	SA2156	SA2176
#400	SA2117	SA2137	SA2157	SA2177
#600	SA2118	SA2138	SA2158	SA2178
#800	SA2119	SA2139	SA2159	SA2179
#100	SA2120	SA2140	SA2160	SA2180

ZIRCONIA DISC WITH PSA BACKING (100 PER BOX)

These Zirconia discs are used on hard-to-grind materials. Fast and clean cutting, they are available in 4 grit sizes and supplied with PSA backing.

Eye protection recommended.

Grit Size	12,000		10,000	
	11	21	31 11	40 11
#60	SA2211	SA2231	SA2251	SA2271
#80	SA2212	SA2232	SA2252	SA2272
#120	SA2213	SA2233	SA2253	SA2273

METAL-BASED DIAMOND DISC WITH PSA BACKING (1 PER BOX)

These metal-based diamond discs are thin metal discs plated with diamond grains. Suitable for various materials such as sintered hard alloy, ceramics, glass, etc. Also supplied with PSA backing.

Eye protection recommended

Grit Size	12,000				10,000			
	11	21	31 11	40 11	11	21	31 11	40 11
#140	SA2811	SA2831	SA2851	SA2871				
#220	SA2812	SA2832	SA2852	SA2872				
#270	SA2813	SA2833	SA2853	SA2873				
#400	SA2814	SA2834	SA2854	SA2874				
#600	SA2815	SA2835	SA2855	SA2875				
#800	SA2816	SA2836	SA2856	SA2876				
#1000	SA2817	SA2837	SA2857	SA2877				
#2000	SA2818	SA2838	SA2858	SA2878				

CLOTH-BASED DIAMOND DISC WITH PSA BACKING (3 PER BOX)

These cloth-based diamond discs are soft cloth discs plated with diamond grains. Suitable for sintered hard alloy, ceramics and glass.

Eye protection recommended

Grit Size / Color	12,000				10,000			
	11	21	31 11	40 11	11	21	31 11	40 11
#120 / Sky Blue	SA2911	SA2931	SA2951	SA2971				
#180 / Orange	SA2912	SA2932	SA2952	SA2972				
#240 / Green	SA2913	SA2933	SA2953	SA2973				
#320 / Purple	SA2914	SA2934	SA2954	SA2974				
#400 / Brown	SA2915	SA2935	SA2955	SA2975				
#600 / Red	SA2916	SA2936	SA2956	SA2976				
#800 / White	SA2917	SA2937	SA2957	SA2977				
#1000 / Pink	SA2918	SA2938	SA2958	SA2978				
#1500 / Blue	SA2919	SA2939	SA2959	SA2979				
#3000 / Yellow	SA2920	SA2940	SA2960	SA2980				

RUBBER DISC WITH PSA BACKING (20 PER BOX)

WA Disc-formed abrasive rubber. These rubber discs are made of high elastic rubber which resists scratching and produces a uniform finish.

Grit Size	SA2731	SA2751	SA2771
#60	SA2731	SA2751	SA2771
#80	SA2732	SA2752	SA2772
#120	SA2733	SA2753	SA2773

FELT DISC WITH PSA BACKING (20 PER BOX)

Thickness 2 mm. These felt discs are compressed dense structures of carefully selected fine quality wool.

These discs should be used with a DiaMold® diamond polishing compound and Hyperlube® lubricant (see Section 1). Rich in elasticity, they fit well in curved surfaces and are applicable to finish polishing.

SA3101	SA3102	SA3103	SA3104
--------	--------	--------	--------

GREEN FELT DISC WITH PSA BACKING (20 PER BOX)

Compound impregnated. Thickness 2 mm. These green felt discs are compressed dense structure of carefully selected fine quality wool impregnated with chromium oxide polishing compound. They are directly applicable to finish polishing, precision polishing and glossing, and require no polishing compounds.

SA3141	SA3142	SA3143	SA3144
--------	--------	--------	--------

FELT DISC WITH SOFT CUSHION WITH PSA BACKING (20 PER BOX)

These felt discs have a soft cushion inserted between the contact surface and felt disc so that they fit well in curved surfaces and enable impact-free polishing.

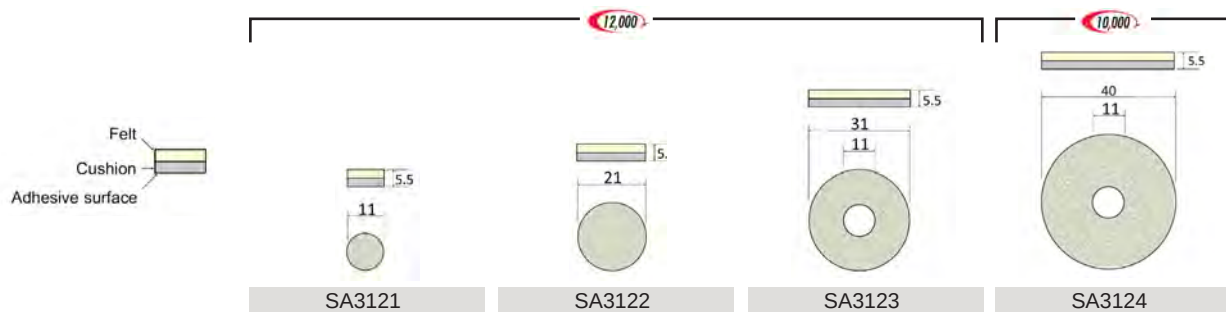

CUSHION DISC NON-WOVEN CLOTH IMPREGNATED WITH POLISHING COMPOUNDS WITH PSA BACKING (20 PER BOX)

These cushion discs have high elasticity and fit well with work pieces. Resultant surfaces are smooth and free of irregularities. They also produce minimal debris and resist clogging, even with fine grains.

Elastic, pliable rubber discs are fit to polish flat and curved surfaces. These are extremely durable.

Eye protection recommended

Grit Size	SA2631	SA2651
#240	SA2631	SA2651
#320	SA2632	SA2652
#400	SA2633	SA2653
#600	SA2634	SA2654
#800	SA2635	SA2655
#1000	SA2636	SA2656
#1500	SA2637	SA2657

Minimo® Recipron Systems

RE112, RE212

The Recipron handpiece generates a reciprocating stroke, ideal for filing, lapping, stoning, polishing and scraping operations. Comfortable hand fitting pistol grip with built-in ON/OFF SWITCH provides greater processing accuracy. Smooth operation, vibration free. Eliminates operation fatigue.

RE112:

- Stroke range: 0 - 8 mm
- Stroke speed: 260 - 3,500 times/min.
- Stroke-oriented type

RE212:

- (Speed model) Stroke range: 0 - 2 mm
- Stroke speed: 460 - 7,000 times/min.
- Speed-oriented type

POWER PACK: Used with C2112 Power Pack.

FEATURES & BENEFITS

- **Slim and smooth body shape allows more accurate processing.**
- **2 modes of the tool holder action. When the spindle securing knob is released, the toolholder will rotate freely, ensuring tools to fit the surface of the workpiece.**
- **Built-in ON/OFF SWITCH.**
- **2 models to choose from.**

The Hand Switch is standard equipment on the pistol-shaped handpiece. To ensure manipulations by the fingertip only, the switch is recessed at a position on the grip where you can easily use it.

Examples of applications below:

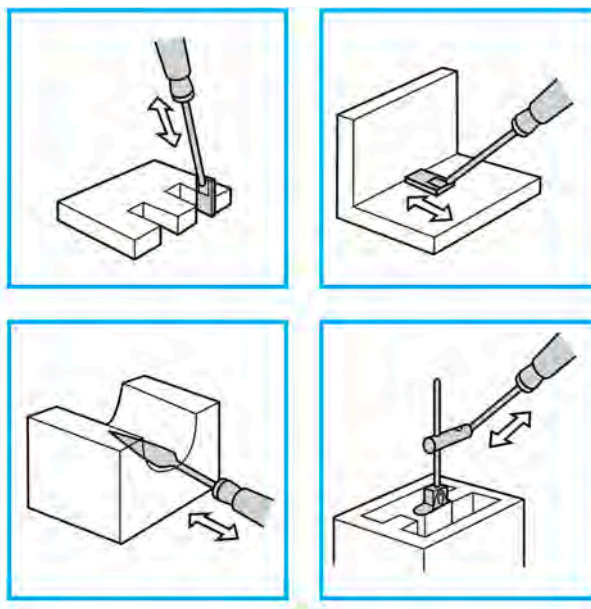

RECIPRON SPECIFICATIONS

	RE112	RE212	Dimensions
Stroke (m/min)	0–8	0–2	
Speed Range (times/min)	260–3,500	460–7,000	
Input Voltage (D. C. V.)	3–30	3–30	
No-load Current (D. C. A.)	0.3	0.35	
Diameter of Mountable Shafts (mm)	2.0–6.35	2.0–6.35	
Carbon Brush	KE-580	KE-580	
Weight (g)	790	783	

Minimo® Mini-Belt Sander

BS312

A handy type belt sander, equipped with ON/OFF SWITCH, that excels in deburring, grinding and polishing.

POWER PACK: Used with C2112 Power Pack.

The main body is equipped with the belt arm H82 as standard; belts with a width of 6 or 8 mm can be used.



Hand Switch enables quick and easy ON/OFF operations

FEATURES & BENEFITS

- Flexibly addresses machining of small parts and objects of complicated shapes.
- A large variety of sanding belts are available that are suitable for various materials including metals, ceramics, stone and wood.
- Quick and easy exchange of belts.
- Optional belt arms are available, which allow you to extend the scope of applications.
- Built-in ON/OFF SWITCH.
- Removable curled power cord makes storage convenient.

BS312 (CONT.)

Examples of applications below:

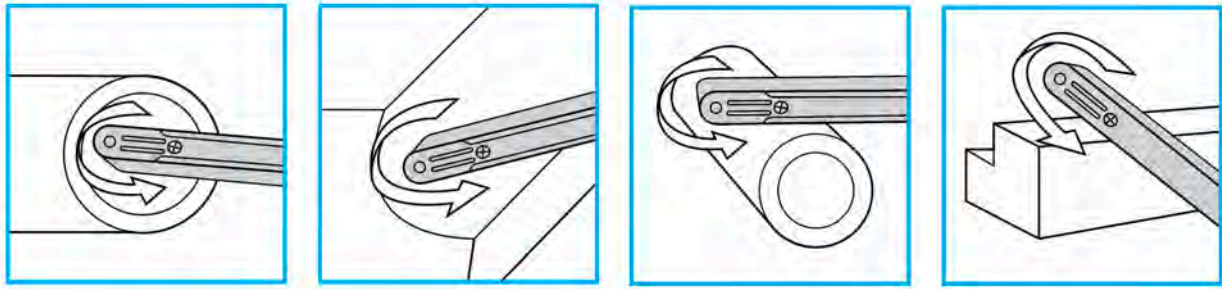

MINI BELT SANDER SPECIFICATIONS

	BS312
No-load Belt Speed (m/min)	49 - 2,700
Input Voltage (D.C.V.)	3-30
No-load Current (D.C.A.)	0.3
Carbon Brush	KE-580
Weight (g)	440

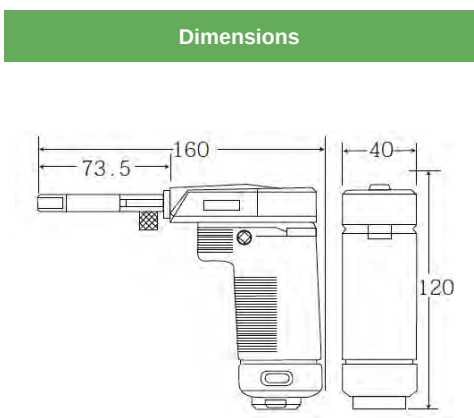

ABRASIVE BELT FOR THE MINI BELT SANDER (CIRCUMFERENCE: 300MM)

Sand Belt (30 Per Box)		Sand Belt (30 Per Box)			
W = 6mm		W = 8mm		W = 8mm	
#80	F1011	#120	F1022	#180	F1121
		#320	F1025	#240	F1122
		#400	F1026	#320	F1123
				#400	F1124
				#600	F1125
				#800	F1126
				#1000	F1127

BELT ARM

Standard Outfit:



H82 Standard belt arm (applicable belt width: 6 and 8 mm)

Option:



H81 Thin belt arm (applicable belt width: 4 and 6 mm)

Minimo® Motors

Ranging from ultra-high speed to the low speed geared type, nine types of micromotors, each with distinctive features, are available in the product line.

The motor and the head can each be purchased separately, or as a complete unit.

KV112H ULTRA-HIGH SPEED MOTOR

TECHNICAL DATA

- Speed Range: 2,000-50,000 RPM
- Torque: 2.3 cN-M
- Carbon brush: KE-605
- Hand Switch Color: Ivory



KM112H HIGH SPEED MOTOR

TECHNICAL DATA

- Speed Range: 1,000-35,000 RPM
- Torque: 3.4 cN-M
- Carbon brush: KE-575
- Hand Switch Color: Violet



KM212H HIGH SPEED MOTOR

TECHNICAL DATA

- Speed Range: 1,000-30,000 RPM
- Torque: 4.2 cN-M
- Carbon brush: KE-580
- Hand Switch Color: Red



KM112 MEDIUM SPEED MOTOR

TECHNICAL DATA

- Speed Range: 1,000-20,000 RPM
- Torque: 4.5 cN-M
- Carbon brush: KE-575
- Hand Switch Color: Blue



KM212 MEDIUM SPEED MOTOR

TECHNICAL DATA

- Speed Range: 1,000-15,000 RPM
- Torque: 5.9 cN-M
- Carbon brush: KE-580
- Hand Switch Color: Green



KM212L LOW SPEED MOTOR

TECHNICAL DATA

- Speed Range: 800-8,000 RPM
- Torque: 6.9 cN-M
- Carbon brush: KE-580
- Hand Switch Color: Black



KM112G LOW SPEED GEAR-TYPE MOTOR

TECHNICAL DATA

- Speed Range: 660-6,600 RPM
- Torque: 9.8 cN-M
- Carbon brush: KE-575
- Hand Switch Color: Yellow



Minimo® Heads

Minimo offers the most complete line of heads for a wide range of applications. Grinding, deburring, drilling, lapping and polishing can be performed using a combination of these heads and motors. The heads and motors are attached in a snap.

H011/E

Standard Head: The most universal head. Standard collets 3/32"(KP-036) and 1/8" (KP-033)



H021/E

Slimmer Head: Slim & lightweight - suitable for delicate processing work. Standard collets 3/32"(KP-036) and 1/8" (KP-033)



H031/E

Heavy-Duty Head: Standard collets 1/8" (KP-063) and 1/4" (KP-064)



Long Slender Head: Ideal for hard to reach areas with reach size 1/2" x 3-7/8". Standard collets 3/32"(KP-036) and 1/8" (KP-033)



H051/E

Air Head: Produces a jet of air around the tool to blow shavings and dust off work area. Standard collets 1/8" (KP-063) and 1/4" (KP-064)



HANDPIECE CROSS REFERENCE FOR MOTORS AND HEADS

Head Selection	Motor Selection								
HO11/E	KV112H		KM112H	KM212H		KM112	KM212	KM212L	KM112G
HO21/E	KV112H		KM112H	KM212H		KM112	KM212	KM212L	KM112G
HO31/E	KM212H		KM212L	KM112G					
HO41/E		KM112H	KM212H		KM112	KM212	KM212L	KM112G	
HO51/E	KV112H		KM112H						
H221/E	KM212	KM212L	KM112G						
H231/E	KM212	KM212L	KM112G						
H311	KM212L	KM112G							

H221/E

TECHNICAL DATA

- Heavy-Duty Anglon Head 90°
- Maximum speed - 15,000 RPM
- Standard Collets 3/32" (KP-036) and 1/8" (KP-033)



H231/E

TECHNICAL DATA

- Heavy Duty Anglon Head 120°
- Maximum speed - 15,000 RPM
- Standard Collets 3/32" (KP-036) and 1/8" (KP-033)



TECHNICAL DATA

- Rubron Head (Adjustable swing up to 1.6 mm at chuck edge)
- Maximum speed - 8,000 RPM



COLLET SELECTION TABLE

Head Model	Collet Code	Inside Diameter
HO11/E	KP-050	1.0
HO21/E	KP-051	1.2
HO41/E	KP-007	1.4
HO51/E	KP-005	1.6
HO51P/E	KP-052	1.8
H221/E	KP-031	2.0
H231/E	KP-036	3/32"
	KP-032	3.0
	KP-033	1/8"
HO31/E	KP-061	3/32"
	KP-062	3.0
	KP-063	1/8"
	KP-066	4.0
	KP-067	5.0
	KP-060	6.0
	KP-064	1/4"
H211/E	KP-021	3/32"
	KP-022	3.0
	KP-025	1/8"

Minimo® Accessories - Power Cords

FOOT SWITCH (CAN BE USED WITH ALL POWER PACKS)

FS201



Features:

- An ON/OFF type foot switch.
- When pressed, the handpiece is on. When released, the handpiece will stop.
- Cord length: 1.5 m / 4'6"

FS211



Features:

- 2-mode changeover type.
- You can perform ON/OFF switching either in mode A or B.
- Cord length: 1.5 m / 4'6"
- A-mode: Once you step on the foot switch, the ON state continues even if you take your foot off the switch; step on it for a second time, and it changes into the OFF state.
- B-mode: When pressed the handpiece is on, when released, the handpiece will stop.

VC301



Features:

- In addition to ON/OFF switching, the speed and power control for the POLYTOR handpiece action is provided depending on how far the pedal is depressed.
- Cord length: 1.5 m / 4'6"

POWER CORD FOR HANDPIECE

Cords for the D.C. motor handpiece (with a 3-pin connector)

CURLED CORD - CC711

TECHNICAL DATA

- Length: 1.5 m / 4'6"
- Power cord for the D.C. motor handpiece
- Standard accessory with the handpiece



CURLED CORD - CC811 - 4 PIN CONNECTOR

TECHNICAL DATA

- Length: 1.5 m / 4'6"
- Power cord for the POLYTOR US21 ultrasonic handpiece
- Standard accessory with POLYTOR ultrasonic handpiece



EXTENSION CORD - CB211

TECHNICAL DATA

- Length: 3 m / 9'6"
- Straight extension cord for connecting the POWER PACK and the curled cord (CC711).
- Two or more extension cords can be connected.



EXTENSION CORD - CB311 - 4 PIN CONNECTOR

TECHNICAL DATA

- Length: 3 m / 9'6"
- Straight extension cord for connecting the POWER PACK and the curled cord (CC811).
- Two or more extension cords can be connected.



POWER CORD FOR POWER PACK

Standard accessory with the POWER PACK

CA10

TECHNICAL DATA

- Length: 2 m / 6'6"
- Power cord for all Minimo Power Packs (AC115V)



Minimo® Accessories - Tool Cases

Aluminum-made Carrying Cases: Conveniently portable, the robust aluminum carrying case houses the POWER PACK, handpieces and other accessories neatly and safely, with a padded interior.

BX01 CARRYING CASE (SMALL)

TECHNICAL DATA

- Outside dimensions: 365 (W) x 210 (D) x 280 (H) mm
- Weight: 2.6kg



BX02 CARRYING CASE (LARGE)

TECHNICAL DATA

- Outside dimensions: 470 (W) x 230 (D) x 340 (H) mm
- Weight: 4.2kg



Minimo® Tool Stand/Rubber Cradle

RUBBER CRADLE - RM11

Provides a safe and convenient resting place for your handpiece when not in use. Helps prevent handpiece damage from accidental drop.

- Cradle made of rubber
- Can be used for all listed handpieces
- Outside dimensions: 72 (W) x 72 (D) x 30 (H) mm

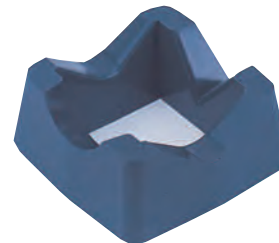

SPHERICAL VISE - V151

This 18.5 lb steel sphere mounted on a rubber base securely holds smaller parts during stoning and polishing operations. No need to clamp this vise to the bench.

- V-shaped grooves on the mouth ensure an even grasp of the workpiece
- Detachable adjusting handle

Spherical Base Specifications

Sphere Diameter	130 mm / 5.118"
Height	65 mm / 2.559"
Base Width	60 mm / 2.362"
Max Mouth Width	62 mm / 2.440"
Sphere Depth	50 mm / 1.968"
Clamping Capacity	44.5 mm / 1.75"
Weight	8.5 kg / 18.75 lbs





ROTARY FINISHING TOOLS

Diamond Compounds
Polishing Lubricants
High-Intensity Polish

Diprofil® Finishing Systems
Tools
Accessories

Diprofil® Files

Minimo® Finishing Systems
Tools
Accessories

Rotary Finishing Tools

Finishing Sticks
Stones
Accessories

Welding Units
Accessories

Rotary Finishing Tools

DIAMOLD® MOUNTED WOOL FELT BOBS (1 PER BOX)

Mandrel Mounted: DiaMold® Felt Bobs are made of pure wool in a broad variety of sizes, shapes and degrees of hardness - for any finishing requirement. The mandrels are exactly centered for true-running operation. When ordering, specify part number and hardness desired.

Ordering Example:

Prefix: 503.
P/N: MS.1A.
Hardness: M*

*M = Medium H = Hard RH = Rock Hard

Standard Shapes in Medium, Hard:

Part No.	Width	Depth	Shank
503.MS.1A	1/2"	1"	1/8"
503.MS.1C	1"	2"	1/4"
503.MS.2A	1/2"	1/2"	1/8"
503.MS.3C	3/8"	1/2"	1/8"
503.MS.3F	1/2"	1"	1/8"
503.MS.4B	1/2"	3/4"	1/8"
503.MS.5A	1/2"	3/4"	1/8"
503.MS.6A	1/2"	1/2"	1/8"

Cylinders - Medium, Hard, Rock Hard

Part No.	Width	Depth	Shank
503.CB.2	1/4"	1/4"	1/8"
503.CB.2A	3/8"	3/8"	1/8"
503.CB.3	3/8"	1/2"	1/8"
503.CB.4	1/2"	1/2"	1/8"
503.CB.5	1/2"	3/4"	1/8"
503.CB.6	1/2"	1"	1/8"
503.CB.7	3/4"	3/4"	1/8"
503.CB.10	1"	1"	1/4"

Felt Reciprocating Bob:



LSB.2.MED

3/8" x 3/8" x 1-1/2"



Max. RPM 15,000

DIAMOLD® FELT BOB ASSORTMENT 503.40

This assortment includes the following:

12 cylinders: 2 each of 4 sizes in each hardness: Medium, Hard, Rock Hard; all 1/8" mandrel

Sizes: CB-2 1/4" x 1/4", CB-3 3/8" x 1/2", CB-4 1/2" x 1/2", CB-7 3/4" x 3/4"

8 standard shapes: 1 each of 4 sizes in Medium & Hard all 1/8" mandrel, 1/2" diameter - MS1A 1/2" x 1", MS2A 1/2" x 1/2", MS3F 1/2" x 1", MS6A 1/2" x 1/2"

6 Felt Finger Pads: 1" x 3" - 1/8" thick

Eye protection recommended



Max. RPM 15,000

DIAMOLD® WOOD BOBS (1 PER BOX)

DiaMold® Bobs are available in Hydulignum, a highly-compressed hard wood laminated in layers with plastic. The grain direction is perpendicular to the circumference to assure uniform lapping surface and efficient charging. They are recommended for fast stock removal or where exact contour or shaping is required - use 15 micron or coarser Engis® Diamond Compounds for these applications. Bobs are also available in selected soft pine for pre-finish before final felt polishing. Diamond Compounds grade of 15 micron or finer are recommended for use with these bobs.



501.HYD.1/SFT



501.HYD.4/SFT.4



501.HYD.2/SFT.2



501.HYD.5/SFT.5



501.HYD.3/SFT.3



501.HYD.6/SFT.6



1/8" Mandrel Mounted Cones and Cylinders:

HYD-1/SFT-1, HYD-2/SFT-2, HYD-3/SFT-3, HYD-4/SFT-4
 HYD-5/SFT-5, HYD-6/SFT-6

Hydulignum (Hard Wood)	Pine (Soft Wood)	Size	Shape
501.HYD.1	501.SFT.1	3/4" x 1-3/16"	Cone
501.HYD.2	501.SFT.2	7/16" x 1-3/16"	Cone
501.HYD.3	501.SFT.3	9/32" x 5/8"	Cone
501.HYD.4	501.SFT.4	3/4" x 1-1/8"	Cylinder
501.HYD.5	501.SFT.5	7/16" x 3/4"	Cylinder
501.HYD.6	501.SFT.6	9/32" x 1/2"	Cylinder

Max. RPM 10,000

DIAMOLD® POLISHING BRUSHES (12 PER BOX)

These top quality brushes will hold diamond compounds longer and provide more cutting action at lower production costs. They are made of natural stiff bristle for long life.

Available in three shapes with long shank for straight handpieces and in three shapes with short shank for contra-angle handpieces.

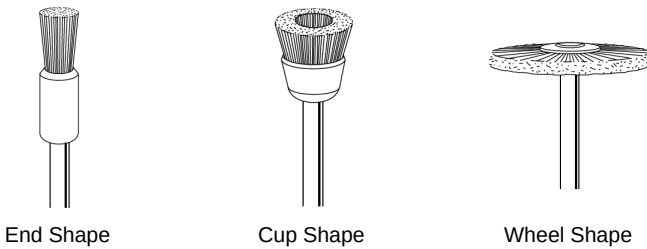

Brush No.	Shank Diameter	Shape	Description
Use these brushes with any Straight Handpiece			
504.7HL	1/8"	End Shape	Plast Ferrule
504.7HS	3/32"	End Shape	Metal Ferrule
504.2HL	1/8"	Wheel Shape	Firm, natural bristles hold shape
504.2HS	3/32"	Wheel Shape	Firm, natural bristles hold shape
504.12HL	1/8"	Cup Shape	More bristles for longer life
504.12HS	3/32"	Cup Shape	More bristles for longer life
Use these brushes with Contra-Angle Handpiece only - for hard-to-get-at places			
504.73RC	3/32"	End Shape	
504.123RC	3/32"	Cup Shape	

ABRA-CAP SEAMLESS THROW-AWAY CAPS (25 CAPS AND 1 HOLDER PER BOX)

For grinding, deburring, tool and die work, and other production operations, Abra-Caps are efficient and economical. They are seamless, with multi-coated abrasives that assure constant cutting efficiency and uniform surface feet per minute. After repeated uses, only the throwaway cap is discarded - no need to waste an entire tool because of dimensional change. The hard rubber holder is never exposed to wear.

17 sizes and shapes in two grit sizes to meet all requirements in working flat and curved surfaces, slots and grooves.



Eye protection recommended

Abra-Cap Replacement Series No. 61

Cap No.	Grit	Cap Diameter	Cap Length	Use Rubber Holder No.
506.5PC	80	.20	.40	506.5P
506.5PF	320			
506.10PC	80	.40	.63	506.10P
506.10PF	320			
506.16PC	80	.63	.79	506.16P
506.16PF	320			
506.5RC	80	.20	.40	506.5R
506.5RF	320			
506.10RC	80	.40	.63	506.10R
506.10RF	320			
506.16RC	80	.63	.79	506.16R
506.16RF	320			
506.5SC	80	.20	.40	506.5S
506.5SF	320			
506.10SC	80	.40	.63	506.10S
506.10SF	320			
506.16SC	80	.63	.79	506.16S
506.16SF	320			

Abra-Cap Replacement Series No. 70

Cap No.	Grit*	Cap Diameter	Cap Smallest Length	Cap Length	Use Rubber Holder No.
506.5.CT	80	.20	.157	6.00	5/4 or 10/4
506.5.FT	150	.20	.157	6.00	5/4 or 10/4
506.10.CT	80	.40	.157	3.30	10/4
506.10.FT	150				
506.11.CT	80	.43	.354	1.00	11/9
506.11.FT	150				15/9
506.15.CT	80	.60	.354	3.30	15/9
506.15.FT	150				
506.16.CT	80	.63	.551	1.25	16/14
506.16.FT	150				20/14
506.20.CT	80	.79	.551	3.30	20/14
506.20.FT	150				
506.22.CT	80	.90	.748	1.60	22/19
506.22.FT	150				25/19
506.25.CT	80	1.00	.784	3.30	25/19
506.25.FT	150				

**All caps in package are of one grit and size*

ABRA-CAP SEAMLESS THROW-AWAY CAPS (25 CAPS AND 1 HOLDER PER BOX) (CONT.)

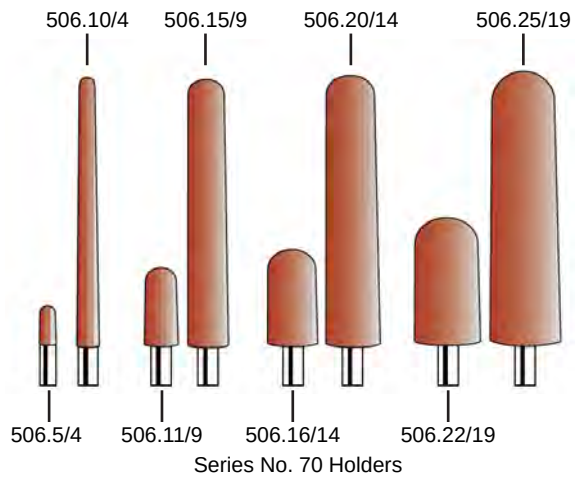

MOUNTED POINTS FOR MOLD AND DIE WORK

Engis® mounted abrasive points are designed specifically for mold and die work and include:

- Popular “B” and “W” shapes in both medium (red) and hard (blue) grades
- Assortments containing the most popular shapes

Points are manufactured from premium aluminum oxide and special bonding materials to assure rapid stock removal and long life.

Ordering and Packaging:

Items shown in these listings are stocked and available for immediate shipment. All items are packaged in quantities of 25.

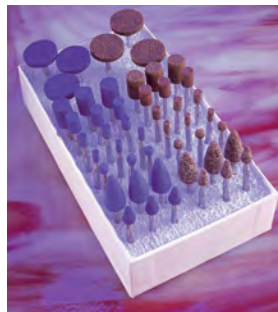

“B” Shapes Red & Blue Grades

“B” SHAPES RED & BLUE GRADES

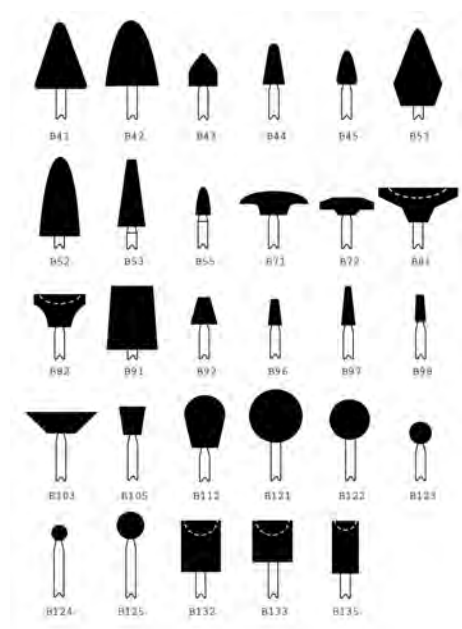

MOUNTED POINTS FOR MOLD AND DIE WORK (CONT.)

"B" Shapes Red (Medium) & Blue (Hard) Grades

Shape	Size (in.) Dia.	Thickness	Mandrel (in.)	Red Grade Item No.	Blue Grade Item No.
B41	5/8	5/8	1/8	204181	204183
B42	1/2	3/4	1/8	204281	204283
B43	1/4	5/16	1/8		204383
B44	7/32	3/8	1/8	204481	204483
B45	3/16	5/16	1/8		204583
B51	7/16	3/4	1/8		205183
B52	3/8	3/4	1/8	205281	205283
B53	1/4	5/8	1/8	205381	205383
B55	1/8	1/4	1/8		205583
B71	5/8	1/8	1/8		207183
B72	1/2	1/8	1/8		207283
B81	3/4	3/16	1/8		208183
B82	1/2	1/4	1/8		208283
B91	1/2	5/8	1/8	209181	
B92	1/4	1/4	1/8	209281	
B96	1/8	1/4	1/8	209681	209683
B97	1/8	3/8	1/8		209783
B98	3/32	1/4	1/8		209883
B103	5/8	3/16	1/8		210383
B105	1/4	1/4	1/8		210583
B112	3/8	1/2	1/8		211283
B121	1/2	1/2	1/8		212183
B122	3/8	3/8	1/8	212281	212283
B123	3/16	3/16	1/8	212381	212383
B124	1/8	1/8	1/8	212481	212483
B125	1/4	1/4	1/8	212581	
B132	3/8	1/2	1/8	213281	
B133	3/8	3/8	1/8		213383
B135	1/4	1/2	1/8	213581	213583

Standard Packaging is 25

Eye protection recommended

MOUNTED POINTS FOR MOLD AND DIE WORK (CONT.)

“W” Shapes Red (Medium) & Blue (Hard) Grades

Shape	Size (in.) Dia.	Thickness	Mandrel (in.)	Red Grade Item No.	Blue Grade Item No.
W140	1/4	5/64	1/8		214083
W141	3/32	5/32	1/8	214181	
W142	3/32	1/4	1/8	214281	214283
W144	1/8	1/4	1/8	214481	214483
W145	1/8	3/8	1/8	214581	214583
W146	1/8	1/2	1/8	214681	214683
W149	5/32	1/4	1/8		214983
W152	3/16	1/4	1/8	215281	
W153	3/16	3/8	1/8	215381	215383
W154	3/16	1/2	1/8	215481	215483
W160	1/4	1/4	1/8	216081	216083
W161	1/4	5/16	1/8		216183
W162	1/4	3/8	1/8	216281	216283
W163	1/4	1/2	1/8	216381	216383
W164	1/4	3/4	1/8		216483
W168	5/16	5/16	1/8		216883
W169	5/16	3/8	1/8	216981	
W170	5/16	1/2	1/8	217081	217083
W175	3/8	3/8	1/8		217583
W176	3/8	1/2	1/8	217681	217683
W178	3/8	1	1/8		217883
W182	1/2	1/8	1/8	218281	
W185	1/2	1/2	1/8		218583
W189	1/2	2	1/4	218941	
W200	3/4	1/8	1/8	220081	220083
W208	3/4	2	1/4	220841	
W216	1	1/4	1/8		221683
W220	1	1	1/4	222041	
W222	1	2	1/4	222241	
W225	1-1/4	1/4	1/4	222541	
W235	1-1/2	1/4	1/4	223541	
W236	1-1/2	1/2	1/4	223641	
W242	2	1	1/4	224241	

Standard Packaging is 25

Kits: **Item Number:**

Kit 1, 48 Points: 299901

Three medium (red) and three hard (blue) each of the following: B44, B52, B96, B123, W144, W152, W162, W170, W175, & W200

Kit 2, 100 Points: 299902

Ten hard (blue) each of the following: B44, B52, B96, B123, W144, W152, W162, W170, W175 & W200

All “W” shapes are basically rectangular or square in their form. The diameter (D) and thickness (T) are detailed in the charts.

Eye protection recommended

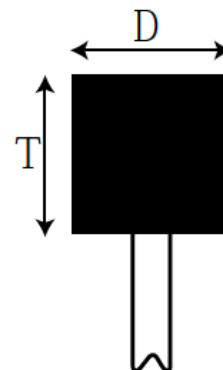

TUNGSTEN-CARBIDE CUTTERS (1 PER BOX)

For use with Air and Electric Rotary Handpieces.









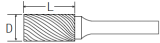

The precision construction and design of the Engis® Tungsten-Carbide cutters makes them ideal for use on all materials from 25 RC thru 65 RC, including brass, cast iron, aluminum, bronze, fiberglass, plastics, etc.

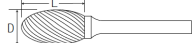
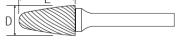
These all-purpose cutters are ideal for hard to reach operations such as dies, small cavities, etc.









Eye protection recommended

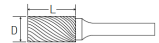

**1/8" Shank Diameter - 1-1/2" Overall Length
Cutting Head**

Part No.	Diameter (D)	Length (L)	
EA1	1/16"	1/4"	
EA2	3/32"	7/16"	
EA3	1/8"	9/16"	
EC4	3/32"	7/16"	
EC5	1/8"	9/16"	
ED6	3/32"	3/32"	
ED7	1/8"	1/8"	
EE8	1/8"	7/32"	
EF9	1/8"	1/4"	
EF10	1/8"	1/2"	
EG11	1/8"	1/4"	
EG12	1/8"	3/8"	
EH13	1/8"	1/4"	
EJ14	1/8"	60°	
EK15	1/8"	90°	
EL16	1/8"	8°	
EL17	1/8"	8°	
EM18	1/8"	12°	
EM19	1/8"	14°	
EM20	1/8"	7°	
EN21	1/8"	10°	

**1/4" Cutting Head Diameter -
1/8" Shank Diameter - 1" Shank Length**

Part No.	Cutting Head Length or Incl. Angle	
EA22	1/2"	
EB23	3/16"	
EC24	1/2"	
ED25	1/4"	
EE26	3/8"	
EF27	1/2"	
EG28	1/2"	
EM29	22°	
EN30	10°	

When ordering, indicate part number and description

DIAMOND WHEELS AND POINTS (1 PER BOX)

Single Layer - 3/32" Shanks

Fifteen shapes and a total of 49 sizes permit a broad selection of single layer diamond wheels and points for every type of grinding job. These tools are precision made with a special bond of metal plating that holds the diamonds in an exposed position for fast, constant cutting action.

- For long shank, used in all straight handpieces, specify "H" in ordering.

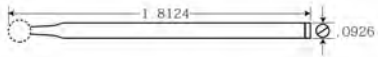

- For short shank, for contra-angle handpiece #55 only, specify "R" in ordering (see * below)

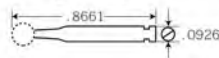

Eye protection recommended

	Part No.	D	d	t/h
A	DT124PH	.602	.512	.018
	DT125PH	.721	.630	.018
	DT126PH	.799	.709	.020
	DT127PH	.878	.787	.020
	DT74APH	.787	.276	.014
B	DT128PH	.361	.276	.020
	DT56PH	.343	.268	.051
	DT132PH	.748	.453	.039
C	DT129PH	.248	-	.020
	DT105PH	.252	-	.035
D	DT107H	.102	-	.118
	DT100H	.098	-	.276
	DT114H	.087	-	.276
	DB305H	.075	-	.196
E	DT111H	.165	-	.059
	DT116H	.232	-	.236
	DT108H	.102	.059	.114
F	DT236H	.287	60°	.236
	DT93H	.201	27°	.374
	DT103AH	.169	80°	.106
	DT94H	.122	31°	.189
	DT117H	.094	-	.295
G	DT510H	.094	-	.394
	DB902AH	.051	-	.158
	DT112H	.161	-	.059
H	DT109H	.366	-	.051
	DB108H	.098	-	-
I	DB102H	.051	-	-
	DB2/0H	.032	-	-
	DB104H	.067	-	-
	DB105H	.071	-	-
	DT101H	.118	-	-
	DT119H	.158	-	-
	K			

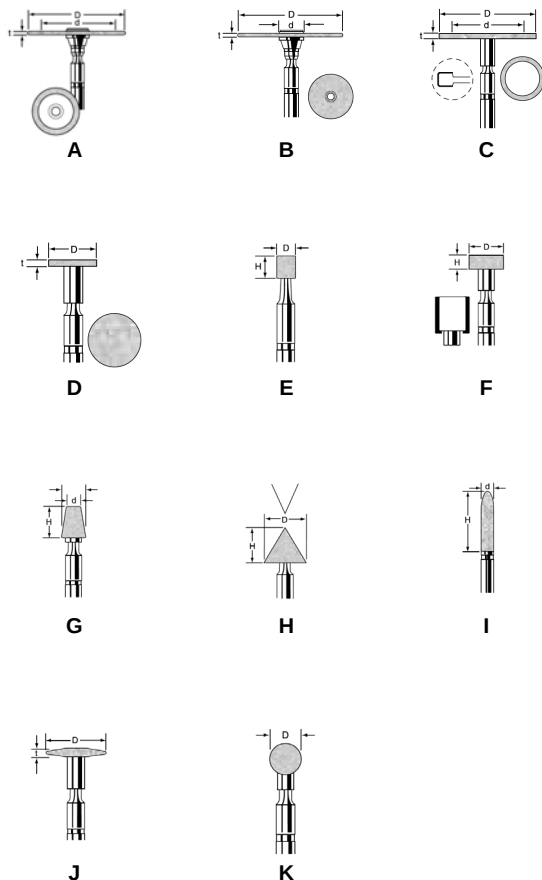

PRECISION PLUS ELECTROPLATED DIAMOND & CBN GRINDING PINS (1 PER BOX)

Featuring hardened steel shanks and bonded diamond or CBN particles, these precision grinding pins are ideal for use on jig and internal grinding machines and/or hand tools. Through our Electrogrip® process, particle exposure is maximized, assuring a free cutting action that greatly reduces heat and wear.

Eye protection recommended

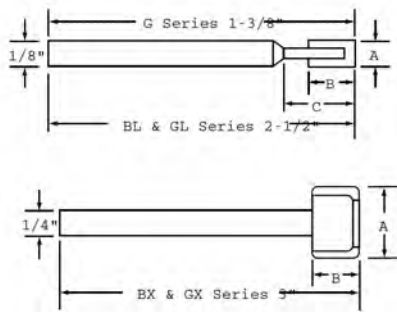

BL (CBN) & GL (DIAMOND) SERIES PINS - SPECIFICATIONS

CBN Grit Size	Catalog Number	Diamond Grit Size	Catalog Number	A	B	C
140/170	BL.20	Coarse (140/170) or Fine (200/230)	GL.20	.020	1/16"	1/8"
	BL.25		GL.25	.025	3/32"	1/4"
	BL.30		GL.30	.030	3/32"	1/4"
	BL.35		GL.35	.035	3/32"	1/4"
80/100	BL.40	Coarse (140/170) or Fine (200/230)	GL.40	.040	1/8"	3/8"
	BL.45		GL.45	.045	1/8"	3/8"
	BL.50		GL.50	.050	1/8"	3/8"
	BL.50-1		GL.50.1	.050	1/8"	1"
	BL.55		GL.55	.055	1/8"	3/8"
80/100	BL.60	Coarse (140/170) or Fine (200/230)	GL.60	.060	1/8"	3/8"
	BL.60.1		GL.60.1	.060	1/8"	1"
	BL.70		GL.70	.070	5/32"	1/2"
	BL.70.1		GL.70.1	.070	5/32"	1"
	BL.80		GL.80	.080	5/32"	1/2"
80/100	BL.80-1	Coarse (100/120) or Fine (200/230)	GL.80.1	.080	5/32"	1"
	BL.90		GL.90	.090	5/32"	1/2"
	BL.90-1		GL.90.1	.090	5/32"	1"
	BL.100		GL.100	.100	5/32"	1/2"
	BL.100.1		GL.100.1	.100	5/32"	1"
	BL.110		GL.110	.110	5/32"	1/2"
	BL.110-1		GL.110.1	.110	5/32"	1"
80/100	BL.125	Coarse (100/120) or Fine (200/230)	GL.125	.125	5/32"	1/2"
	BL.125-1		GL.125.1	.125	5/32"	1"
	BL.141		GL.141	.141	1/4"	-
	BL.156		GL.156	.156	1/4"	-
	BL.188		GL.188	.188	1/4"	-
	BL.218		GL.218	.218	1/4"	-
80/100	BL.250/2	Coarse (100/120) or Fine (200/230)	GL.250.2	.250	1/4"	-
	BL.250/4		GL.250.4	.250	1/4"	-

When ordering: Specify catalog number and grit size. Special pins quoted upon request (please furnish print or sketch)

MOUNTED POINTS FOR MOLD AND DIE WORK (CONT.)

These diamond-plated taper pins are ideal for grinding or ripping tungsten carbide drawing dies for the wire and ube industries, and for cold heading dies. You get fast, efficient and precise grinding, with long wear.

Eye protection recommended

Specifications:

Part No.	A	B	C
GLT.125.10	1/8"	2-1/2"	10°
GLT.125.12	1/8"	2-1/2"	12°
GLT.125.16	1/8"	2-1/2"	16°
GLT.125.26	1/8"	2-1/2"	26°
GLT.250.10	1/4"	3"	10°
GLT.250.12	1/4"	3"	12°
GLT.250.16	1/4"	3"	16°
GLT.250.26	1/4"	3"	26°



G (DIAMOND) SERIES PINS — SPECIFICATIONS

Diamond Grit Size	Catalog Number	A	B	C
Coarse (140/170) or Fine (200/230)	G.20	.020	1/16"	1/8"
	G.25	.025	3/32"	1/4"
	G.30	.030	3/32"	1/4"
	G.35	.035	3/32"	1/4"
Coarse (100/120) or Fine (200/230)	G.40	.040	1/8"	3/8"
	G.45	.045	1/8"	3/8"
	G.50	.050	1/8"	3/8"
	G.55	.055	1/8"	3/8"
	G.60	.060	1/8"	3/8"
Coarse (100/120) or Fine (200/230)	G.70	.070	5/32"	1/2"
	G.80	.080	5/32"	1/2"
	G.90	.090	5/32"	1/2"
	G.100	.100	5/32"	1/2"
	G.110	.110	5/32"	1/2"
	G.125	.125	5/32"	1/2"

When ordering: Specify grit desired; 80/100 Coarse or 200/230 Fine.
Price sheet available on request.

BX (CBN) & GX (DIAMOND) SERIES PINS - SPECIFICATIONS

CBN Grit Size	Catalog Number	Diamond Grit Size	Catalog Number	A	B
80/100	BX.141	Coarse (100/120) or Fine (140/170)	GX.141	9/64"	1/4"
	BX.156		GX.156	5/32"	1/4"
	BX.188		GX.188	3/16"	1/4"
	BX.218		GX.218	7/32"	1/4"
	BX.250.2		GX.250.2	1/4"	1/8"
	BX.250.4		GX.250.4	1/4"	1/4"
	BX.312.2		GX.312.2	5/16"	1/8"
	BX.312.4		GX.312.4	5/16"	1/4"
	BX.312.6		GX.312.6	5/16"	3/8"
	80/100		BX.375.2	Coarse (100/120) or Fine (140/170)	GX.375.2
BX.375.4		GX.375.4	3/8"		1/4"
BX.375.6		GX.375.6	3/8"		3/8"
BX.500.4		GX.500.4	1/2"		1/4"
BX.500.6		GX.500.6	1/2"		3/8"
BX.500.8		GX.500.8	1/2"		1/2"
BX.750.4		GX.750.4	3/4"		1/4"
BX.750.8		GX.750.8	3/4"		1/2"

Engis® Superabrasive Tools

SUPERABRASIVE TOOLS®

Engis® Electroplated Products

Engis® offers state-of-the-art technology in the design of flat lapping systems that meet the most demanding requirements.

Engis® specializes in the design and manufacture of custom electroplated products, bringing our application and manufacturing experience together to provide high quality products, which exhibit superior performance, even in the most demanding applications.

Electrogrip® diamond and CBN electroplated grinding wheels and cutting tools are engineered to your exact requirements and designed to deliver unsurpassed productivity with consistent quality. We offer tailor-made grinding wheels, pins, dressing blocks and more specialty items.

We offer a complete range of superabrasive electroplated products for precision applications. Engis® also manufactures electroplated products for more demanding applications such as ceramics, fiberglass pipe, and composites.

- Superabrasive wheels
- Diamond blocks & tools
- Diamond pins & mandrels
- Diamond saw blades
- Specialized tools

At Engis® we work hand-in-hand with you to design grinding products for even the most demanding applications. This can include the grinding of gray iron parting lines, threading of fiberglass oil field pipe, precision grinding of high nickel alloy jet engine components, or the final pass on surgical needles.

Contact your Engis® Regional Sales Manager or local distributor to discuss the difficult applications that you may be facing.





FINISHING STICKS

Diamond Compounds
Polishing Lubricants
High-Intensity Polish

Diprofil® Finishing Systems
Tools
Accessories

Diprofil® Files

Minimo® Finishing Systems
Tools
Accessories

Rotary Finishing Tools

Finishing Sticks
Stones
Accessories

Welding Units
Accessories

DiaMold® Lapping Sticks

DIAMOLD® LAPPING STICKS

Hard Wood Lapping Sticks:

Laminated 6" lapping sticks are designed especially for fast stock removal using Engis® diamond compounds. Made of highly compressed wood layers with alternating grain direction, saturated and bonded with synthetic resin, they are dense, easily formed, shape retaining, and perform like a cast iron lap of top quality such as Meehanite. The many shapes available include square and rectangular with 45° bevels or round with conical points.

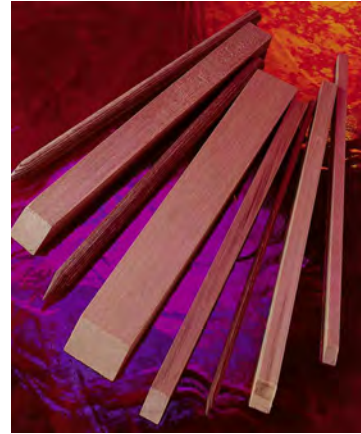

Soft Wood Lapping Sticks:

Designed for immediate and final polishing. Square and rectangular shapes are beveled to 45°; round sticks are pointed. All shapes are 6" long.

Wood Selection		All One Size and Wood Hardness Contained in Each Package		
Hard	Soft	In Each Pack	Size	Shape
502.D	502.SD	1	1/8" x 1/8" x 6"	Square
502.E	502.SE	1	1/8" x 1/4" x 6"	Rectangle
502.F	502.SF	1	1/4" x 1/4" x 6"	Square
502.G	502.SG	1	3/16" x 3/16" x 6"	Square
502.H	502.SH	1	5/16" x 1/2" x 6"	Rectangle
502.I	502.SI	1	5/16" x 3/4" x 6"	Rectangle
502.J	502.SJ	1	1/8" x 6"	Round
502.K	502.SK	1	3/16" x 6"	Round
502.L	502.SL	1	1/4" x 6"	Round

SPECIAL GROUP COMBINATIONS OF LAPPING STICKS

Wood Selection		All One Size and Wood Hardness Contained in Each Package		
Hard	Soft	In Each Pack	Size	Shape
Group 502.A	Group 502.SA	6	1/8" x 1/8" x 6"	Square
		6	1/8" x 1/4" x 6"	Rectangle
		4	1/4" x 1/4" x 6"	Square
		4	3/16" x 3/16" x 6"	Square
		2	5/16" x 1/2" x 6"	Rectangle
Group 502.B	Group 502.SB	2	5/16" x 3/4" x 6"	Rectangle
		12	1/8" x 1/8" x 6"	Square
		12	1/8" x 1/4" x 6"	Rectangle
Group 502.C	Group 502.SC	12	1/4" x 1/4" x 6"	Square
		5	5/16" x 1/2" x 6"	Rectangle
Group 502.M	Group 502.SM	5	5/16" x 3/4" x 6"	Rectangle
		10	1/8" x 6"	Round
		8	3/16" x 6"	Round
		4	1/4" x 6"	Round

DiaMold® Polishing Stones

Engis® offers a complete range of vitrified finishing stones for hand and machine polishing applications. Our stones come in a wide variety of grit sizes and formulations to provide you with the right tool for each job.

DiaMold® stones are available in both standard and premium white aluminum oxide as well as green silicon carbide to cover a broad range of mold materials. Please consult the chart below to identify the right stone for your application.

All of our stones are manufactured in the USA.

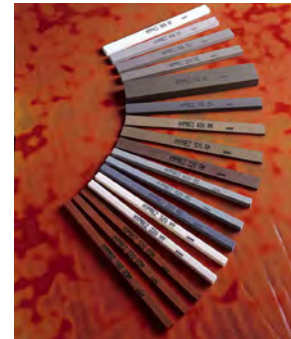

Page	Type	Abrasive	Color	Grits	Characteristics & Application
87	DM	Aluminum Oxide	Gray	150-600	Similar to the DS general purpose finishing stone. This stone is slightly harder and does not break down as rapidly as the DS. Engineered to cut very fast, yet provide a smooth finish. Excellent for removing cutter marks on all tool and die steels.
87	EDM	White Aluminum Oxide	Dark Brown	100-600	The EDM stone is engineered for the removal of EDM scale. This stone is a soft grade which breaks down fast and cuts freely. Specially designed for hand applications.
88	RG	Green Silicon Carbide	Green	120-600	A medium stone with premium silicon carbide grains. Cuts very fast, yet provides an excellent finish on most die and mold steel types ranging from 28 to 58 Rc. Also permits finishing on aluminum, cast iron and bronze.
88	DS	Regular Aluminum Oxide	Green / Tan	100-900	Very popular medium hard stone for all types of steel. Fast cutting, provides a fine, even finish and has the perfect breakdown for a finishing stone.
89	A/L	White Aluminum Oxide	Tan	150-600	A specially treated, medium hard stone that cuts fast and leaves an excellent finish. It works well on aluminum, not scratching or tearing the surface.
90	HY	White Aluminum Oxide	Cream / Ivory	120-600	Extremely well liked, this medium hard stone is treated with a special oil to resist loading. Cuts very fast yet provides smooth finishes on most tool and die sheets. 220 grit and 320 grits work well on hard EDM scale.

DM

Similar to the DS general purpose finishing stone. This aluminum oxide stone is slightly harder and does not break down as rapidly as the DS. Engineered to cut very fast yet provides a smooth finish.

Excellent for removing cutter marks on all tool and die steels.

- General purpose
- Fast cutting
- Consistent breakdown
- For use on all tool steels



Size (inch)	Pcs/ Box	150	180	220	320	400	600
1/16 x 1/4 x 6	12	0810179		0812039	0813239	0814059	0816119
1/16 x 1/2 x 6	12	0810129		0812109	0813249	0814099	0816209
1/8 x 1/8 x 6	12	0810159	0811129	0812159	0813299	0814129	0816259
1/8 x 1/4 x 6	12	0810199	0811179	0812239	0813339	0814199	0816299
1/8 x 1/2 x 6	12	0810229	0811239	0812259	0813359	0814219	0816319
1/8 x 1 x 6	12	0810259	0811289	0812319	0813369	0814229	0816339
5/32 x 5/32 x 6	12	0810309	0811359	0812359	0813399	0814259	0816399
1/4 x 1/4 x 6	12	0810379	0811399	0812369	0813409	0814369	0816409
1/4 x 1/2 x 6	12	0810429	0811429	0812429	0813429	0814429	0816429
1/4 x 1 x 6	6	0810459	0811499	0812739	0813499	0814499	0816469
3/8 x 3/8 x 6	12	0810489		0812789	0813539	0814529	0816559
1/2 x 1/2 x 6	6	0810539	0811549	0812839	0813549	0814559	0816629
1/2 x 1 x 6	4	0810579	0811579	0812869	0813559	0814609	0816649
1 x 1 x 6	2	0810629	0811639	0812899	0813599	0814659	0816699
1/4 TRI x 6	6	0810659		0812909	0813619	0814699	
3/8 TRI x 6	6	0810699		0812919	0813649	0814709	
1/4 RND x 6	6	0810739		0812959	0813679	0814889	0816709
3/8 RND x 6	6	0810789		0812979	0813719	0814899	0816759
1/2 RND x 6	6	0810999		0812999	0813749	0814959	

EDM

The EDM stone is engineered for the removal of EDM scale. This white aluminum oxide stone is a soft grade which breaks down fast and cuts freely. Specially designed for hand application.

Size (inch)	Pcs/ Box	100	120	150	180	220
1/16 x 1/4 x 6	12		0212609	0213709	0214809	0215909
1/16 x 1/2 x 6	12	0211609	0212709	0213809	0214909	0216009
1/8 x 1/8 x 6	12				0215009	0216109
1/8 x 1/4 x 6	12	0211809	0212909	0214009	0215109	0216209
1/8 x 1/2 x 6	12	0211909	0213009	0214109	0215209	0216309
1/8 x 1 x 6	12	0212009	0213109	0214209	0215309	0216409
5/32 x 5/32 x 6	12		0213209		0215409	0216509
1/4 x 1/4 x 6	12	0212309	0213409	0214509	0215609	0216709
1/4 x 1/2 x 6	12	0212409	0213509	0214609	0215709	0216809
1/4 x 1 x 6	6	0212509	0213609	0214709	0215809	0216909

EDM (CONT.)

Size (inch)	Pcs/ Box	280	320	400	600
1/16 x 1/4 x 6	12	0217009	0218109	0219209	0221409
1/16 x 1/2 x 6	12	0217109	0218209	0219309	0221509
1/8 x 1/8 x 6	12		0218309	0229409	0221609
1/8 x 1/4 x 6	12	0217309	0218409	0219509	0221709
1/8 x 1/2 x 6	12	0217409	0218509	0219609	0221809
1/8 x 1 x 6	12	0217509	0218609	0219709	
5/32 x 5/32 x 6	12		0218709	0219809	0222009
1/4 x 1/4 x 6	12	0217809	0218909	0220009	0222209
1/4 x 1/2 x 6	12	0217909	0219009	0220109	0222309
1/4 x 1 x 6	6	0218009	0219109	0220209	0222409

RG

A medium stone with premium silicon carbide grains. Cuts very fast, yet provides an excellent finish on most die and mold steel types ranging from 28 to 58 Rc. Also permits finishing on aluminum, cast iron and bronze.

Size (inch)	Pcs/ Box	120	150	220	320	400	600
1/16 x 1/2 x 6	12		0352059	0353059	0355059	0356059	0358059
1/8 x 1/4 x 6	12	0351139	0352139	0353139	0355139	0356139	0358139
1/8 x 1/2 x 6	12	0351179	0352179	0353179	0355179	0356179	0358179
5/32 x 5/32 x 6	12				0355259	0358259	0358259
1/4 x 1/4 x 6	12	0351299	0352299	0353299	0355299	0356299	0358299
1/4 x 1/2 x 6	12	0351339	0352339	0353339	0355339	0356339	0358339
1/4 x 1 x 6	6		0352379	0353379	0355379	0356379	0358379
3/8 x 3/8 x 6	12		0352419	0353419	0355419	0356419	
1/2 x 1/2 x 6	6		0352459	0353459	0355459	0356459	0358459
1/2 x 1 x 6	4		0352499	0353499	0355499	0356499	0358499
1 x 1 x 6	2		0352539	0353539	0355539	0356539	0358539
1/4 RND x 6	6			0353739	0355739	0356739	

DS

Very popular medium hard aluminum oxide stone for all types of steel. Fast cutting - provides a fine, even finish and has the perfect breakdown for a finishing stone.

Size (inch)	Pcs/ Box	100	150	180	220	280
1/16 x 1/4 x 6	12	0232109	0233409		0236009	0237309
1/16 x 1/2 x 6	12	0232209	0233509		0236109	
1/8 x 1/8 x 6	12	0232309	0233609	0234909	0236209	
1/8 x 1/4 x 6	12	0232409	0233709	0235009	0236309	0237609
1/8 x 1/2 x 6	12	0232509	0233809	0235109	0236409	0237709
1/8 x 1 x 6	12	0232609	0233909	0235209	0236509	0237809
5/32 x 5/32 x 6	12	0232709	0234009	0235309	0236609	
1/4 x 1/4 x 6	12	0232909	0234209	0235509	0236809	0238109
1/4 x 1/2 x 6	12	0233009	0234309	0235609	0236909	0238209
1/4 x 1 x 6	6	0233109	0234409	0235709	0237009	0238309
3/8 x 3/8 x 6	12	0233159	0234459		0237059	0238359
1/2 x 1/2 x 6	6	0233209	0234509	0235809	0237109	0238409
1/2 x 1 x 6	4	0233309	0234609	0235909	0237209	0238509
1 x 1 x 6	2	0233319	0234619	0235919	0237219	
1/4 TRI 6	6		0234639		0237239	
3/8 TRI x 6	6		0234649		0237249	
1/4 RND x 6	6		0234669		0237269	
1/2 RND x 6	6		0234689		0237289	
3/8 RNDx 6	6		0234679		0237279	

DS (CONT.)

Size (inch)	Pcs/ Box	320	400	600	900
1/16 x 1/4 x 6	12	0238609	0239909	0242509	
1/16 x 1/2 x 6	12	0238709	0240009	0242609	
1/8 x 1/8 x 6	12	0238809	0240109	0242709	
1/8 x 1/4 x 6	12	0238909	0240209	0242809	0245409
1/8 x 1/2 x 6	12	0239009	0240309	0242909	0245509
1/8 x 1 x 6	12	0239109	0240409	0243009	
5/32 x 5/32 x 6	12	0239209	0240509	0243109	0245709
1/4 x 1/4 x 6	12	0239409	0240709	0243309	0245909
1/4 x 1/2 x 6	12	0239509	0240809	0243409	0246009
1/4 x 1 x 6	6	0239609	0240909	0243509	0246109
3/8 x 3/8 x 6	12	0239659	0240959	0243559	
1/2 x 1/2 x 6	6	0239709	0241009	0243609	0246209
1/2 x 1 x 6	4	0239809	0241109	0243709	
1 x 1 x 6	2	0239819	0241119	0243719	
1/4 TRI x 6	6	0239839	0241139		
3/8 TRI x 6	6	0239849	0241149		
1/4 RND x 6	6	0239869	0241169	0243769	
1/2 RND x 6	6	0239889	0241189		
3/8 RNDx 6	6	0239879	0241179	0243779	

A/L

A specially treated, medium hard white aluminum oxide stone that cuts freely and leaves an excellent finish. It works well on aluminum, not scratching or tearing the surface.

Size (inch)	Pcs/ Box	150	220	320	400	600
1/8 x 1/4 x 6	12	0381929	0383529	0384329	0385129	0385929
1/8 x 1/2 x 6	12	0381969	0383569	0384369	0385169	0385969
1/4 x 1/4 x 6	12	0382089	0383689	0384489	0385289	0386089
1/4 x 1/2 x 6	12	0382129	0383729	0384529	0385329	0386129
1/4 x 1 x 6	6	0382169	0383769	0384569	0385369	0386169

HY

Favored by professionals, this medium hard white aluminum oxide stone is treated with a special oil to resist loading. It cuts very fast yet provides smooth finishes on most tool and die sheets. 220 grit and 320 grits work well on hard EDM scale.

Size (inch)	Pcs/ Box	120	150	220	320	400	600
1/16 x 1/4 x 6	12	0331019	0332019	0334019	0336019	0337019	0339019
1/16 x 1/2 x 6	12	0331059	0332059	0334059	0336059	0337059	0339059
1/8 x 1/8 x 6	12	0331099	0332099	0334099	0336099	0337099	0339099
1/8 x 1/4 x 6	12	0331139	0332139	0334139	0336139	0337139	0339139
1/8 x 1/2 x 6	12	0331179	0332179	0334179	0336179	0337179	0339179
1/8 x 1 x 6	12	0331219	0332379	0334219	0336219	0337219	
5/32 x 5/32 x 6	12	0331259	0332259	0334259	0336259	0337259	0339259
1/4 x 1/4 x 6	12	0331299	0332299	0334299	0336299	0337299	0339299
1/4 x 1/2 x 6	12	0331339	0332339	0334339	0336339	0337339	0339339
1/4 x 1 x 6	6	0331379	0332219	0334379	0336379	0337379	0339379
3/8 x 3/8 x 6	12	0331419	0332419	0334419	0336419	0337419	
1/2 x 1/2 x 6	6	0331459	0332459	0334459	0336459	0337459	0339459
1/2 x 1 x 6	4	0331499	0332499	0334499	0336499	0337499	0339499
1 x 1 x 6	2	0331539	0332539	0334539	0336539	0337539	0339539
1/4 TRI x 6	6				0336699	0337699	
3/8 TRI x 6	6	0331739		0334739		0337739	
1/2 TRI x 6	6	0331779					
1 TRI x 6	4	0331819					
1/4 RND x 6	6	0331899	0332899	0334899	0336899	0337899	0339899
3/8 RND x 6	6	0332939		0334939	0336939	0337939	0339939
1/2 RND x 6	6			0334979	0336979	0337979	0339979

POLISHING STONE APPLICATION CHART

		Surface					Method			Use	
		Tool Steel	Aluminum	Non-Ferrous	Stainless Steel	EDM	Hand	Profilor	Ultrasonic	Dry	Wet
EDM Stone	EDM	●				●	●	●		●	●
General Purpose	DS	●	●	●	●		●	●		●	●
	RB	●	●				●	●		●	●
	DM	●	●	●	●		●	●		●	●
Specialty Stones	A/L	●	●				●	●			●
	HY	●				●	●	●			●
	ROM	●					●	●		●	●
Silicon Carbide Stone	RG	●	●	●			●	●		●	●

DiaMold® Ceramic Stones

DiaMold® ceramic stones are made from the finest ceramic fiber with a special resin binder and were originally developed for the aerospace industry. These virtually unbreakable polishing stones work well in the finishing of small detail areas such as slots, ribs and other narrow areas of molds and dies. They can be used either by hand or with a reciprocating or ultrasonic Diprofil® polishing system.

Since these high quality ceramic stones can be easily shaped and come in a broad range of sizes and grits, they are one of the most versatile tools for precision finishing of molds and dies.

Usage:

- Precision finishing of ribs, edges, etc., on dies and molds.
- No loading or clogging of the stone even on some materials such as aluminum.
- Can be used in very narrow areas without the risk of breakage.
- Can be used on complex shapes where uniform finishing can be a challenge.
- Can be used by hand or with Diprofil reciprocating or rotary systems.

Stone Holders



TECHNICAL DATA

- High strength, resists breakage
- High efficiency
- Uniform finishes
- Resists loading or clogging
- Low heat generation
- Efficient cleaning of EDM scale
- Fast removal of fine burrs
- Variety of grits available

Number	Length	Width of Stick	
29950	For Profiler	1/8" Mandrel	A
29925	5-1/2"	3mm round	B
29940	5-3/4"	8-10mm stick	C
29935	5-3/4"	6mm stick	D
29930	5-3/4"	2-4mm stick	E
29945	Set of above three		

Shape	Size (mm)	Green 120 Grit P/N	Gold 180 Grit P/N	Orange 220 Grit P/N	Light Brown 300/320 Grit P/N	Orange 400 Grit P/N
Flat	1 x 4 x 50	CS120.10	CS180.10			
Flat	.5 x 2 x 100	CS120.15	CS180.15	CS052100DB	CS300.15	CS400.15
Flat	.5 x 4 x 100	CS054100G	CS054100LB		CS300.20	CS400.20
Flat	.5 x 6 x 100	CS120.25	CS180.25		CS300.25	CS400.25
Flat	.8 x 4 x 100	CS120.30	CS180.30		CS300.30	CS084100B
Flat	.8 x 6 x 100	CS120.35	CS086100LB		CS086100DB	CS086100B
Flat	.8 x 10 x 100	CS120.40	CS180.40		CS300.30	
Flat	1 x 2 x 100	CS120.45	CS180.45		CS12100DB	CS12100B
Flat	1 x 4 x 100	CS14100G	CS14100LB		CS14100DB	CS14100B
Flat	1 x 6 x 100	CS16100G	CS180.55		CS300.55	CS400.55
Flat	1 x 10 x 100	CS120.60	CS110100LB	CS110100O	CS110100DB	CS110100B
Flat	1.5 x 4 x 100	CS120.65	CS180.65		CS300.65	CS400.65
Flat	1.5 x 6 x 100	CS120.70	CS180.70		CS300.70	CS156100B
Round	2.35 x 50					CS400.75
Round	3 x 50	CS120.80	CS180.80		CS300.80	CS400.80
Round	3.16 x 50	CS120.85	CS180.85		CS300.85	CS400.85
Round	3 x 100	CS120.90	CS3100LB		CS300.90	CS400.90

Shape	Size (mm)	Black 600 Grit P/N	Blue 800 Grit P/N	White 1000 Grit P/N	Red 1200 Grit P/N
Flat	1 x 4 x 50	CS600.10	CS800.10		
Flat	.5 x 2 x 100	CS600.15	CS800.15	CS1000.15	CS1200.15
Flat	.5 x 4 x 100	CS600.20	CS800.20	CS1000.20	CS1200.20
Flat	.5 x 6 x 100	CS600.25	CS800.25	CS056100R	CS1200.25
Flat	.8 x 4 x 100	CS600.30	CS800.30	CS1000.30	CS1200.30
Flat	.8 x 6 x 100	CS600.35	CS800.35	CS1000.35	CS1200.35
Flat	.8 x 10 x 100	CS600.40	CS800.40	CS1000.40	
Flat	1 x 2 x 100	CS600.45	CS800.45	CS1000.45	CS1200.45
Flat	1 x 4 x 100	CS600.50	CS800.50	CS14100R	CS1200.50
Flat	1 x 6 x 100	CS600.55	CS800.55	CS1000.55	CS1200.55
Flat	1 x 10 x 100	CS600.60	CS110100W	CS110100R	CS1200.60
Flat	1.5 x 4 x 100	CS600.65	CS800.65	CS1000.65	CS1200.65
Flat	1.5 x 6 x 100	CS600.70	CS800.70		
Round	2.35 x50	CS600.75	CS800.75		CS1200.75
Round	3 x 50	CS600.80	CS800.80	CS1000.80	CS1200.80
Round	3.16 x 50	CS600.85	CS800.85	CS1000.85	CS1200.85
Round	3 x 100	CS600.90	CS800.90	CS3100R	CS1200.90

DiaMold® Polishing Stone Holders

A selection of Polishing Stone Holders is available from Engis®. Holders for hand and machine polishing are listed below.



Part No.		
A	299239	Profiler vise type stone holder, 3/16" shank - for Profiler
B	299249	Profiler vise type stone holder, 1/8" shank - for Profiler
C	299609	Holder Pro for 1/4" Stone (Long), 3/16" shank - for Profiler
D	299639	Holder Pro for 1/4" Stone (Short), 3/16" shank - for Profiler
E	299679	Holder Pro for 1/8" Stone (Short), 3/16" shank - for Profiler
F	299549	Holder Pro for 1 mm ceramic stone, 3/16" shank
G	29915	4 piece hand stone holder kit. Holds round & all sizes of square & rectangular polishing stones from 1/16" to 1/2"
K	299199	1/8" x 1/2" & 1/4" x 1/4" - 1/8" Shank - for Profiler
L	299189	1/8" x 1/4" - 1/8" Shank - for Profiler
M	299169	1/8" x 1/4" - 3/16" Shank - for Profiler
N	299179	1/8" x 1/4" & 1/4" x 1/4" - 3/16" Shank - for Profiler

Stones, Lapping Stick & File Holders

The DiaMold® Stone and Stick Holder (VEA) will hold sticks and stones up to 1/2" diameter, round, square and rectangular at an angle for those hard-to-reach operations (45 to 90° angles).

The VEA is used with the Di-Profiler Reciprocating Hand Machine. It is designed to add greater flexibility to lapping operations.

- A. FH.1 - File Holder
- B. VEA - Stick & Stone Holder
- C. FVA - File & Shoe Holder
- D. 29950 - Hyprez Ceramic Stone Holder
- E. IF-20 - File Holder

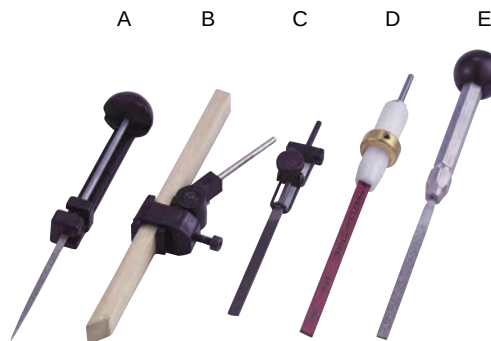

STONE HOLDER KIT WITH ACCESSORIES – PART NO. 508.SHK 101

Kit includes one of each:

- Holder VEA
- Abrasive Stones: 1/4" x 1/2" x 6" (Stone Part Numbers: 0249109, 0254709, 0356339, 0358339, 0286409)
- Hyprez Lapping Sticks: D, SE, F, SG, H, SJ, K and SL

SST Microwelding - LASER QUALITY

Specializing for more than thirty years in microwelding equipment, SST Microwelders offer plasma arc spot welding, TIG, and high speed spot welding.

LASE ONE 300i - THE MOST POWERFUL WELDING SOLUTION OF THE LASE ONE RANGE

Lase One 300i includes:

- Welding generator Lase One 300 joules
- Stereo binocular microscope with articulated arm, equipped with controlled shutter (zoom X4/X20 with cold lighting by LED)
- 2 wrist foam rests
- Microwelding torch (length: 1.5M)
- Foot control pedal (length: 2.0M)
- Accessories for microwelding torch
- Ground cable (length: 2.0M)
- Power supply: 220/240V, single phase + ground

FEATURES & BENEFITS

- Plasma arc spot welding (0-300 joules)
- Weld time adjustable to the tenth of a millisecond (pulse duration 0.1 to 10 ms)
- Weld quality and aspect very similar to that of laser weld
- Welding of ferrous/ non-ferrous/ precious materials (gold, silver, etc.)
- No overheating/ deformations
- Reliable and easy to use
- Economical and safe
- Easy assembly and repair welds of very small as well as large parts
- Programmable

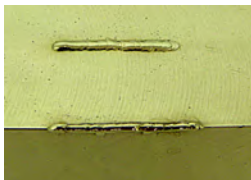

Bronze

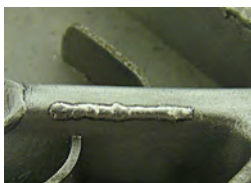

Aluminum



Steel

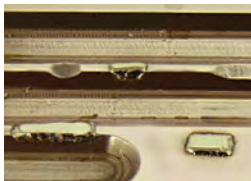

Copper



ELECTRODES SHARPENER

Electrical portable grinder for Lase One electrodes, reliable and easy to use with variable speed control. The high quality of sharpening improves starting arc, especially for precise low intensity discharge. Diamond disk for spare parts available ref L1-DRAFLC.

TECHNICAL DATA

- Precise sharpening in longitudinal direction, through a replaceable diamond cutting wheel
- Standard sharpening angle of 30°
- Power supply: 110/230V - 50/60Hz
- Max. speed 20,000 rpm
- Delivered with electrode holding pencil



Electrode sharpener : L1-AFLC
Diamond disk : L1-DRAFLC

CONTROLLED SHUTTER WELDING MASK

TECHNICAL DATA

- Welding helmet for Lase One generator
- Lenses x 2.5 magnification
- LCD shutter generator unit driven



L1-MS

CART

Mobile serving cart equipped by electric cylinder operated by remote control. To use with extended cables.



CART

CLEANING PEN

Fiber glass cleaning pen for micro-welding, including one refill.



Cleaning pen : SST-CN
Set of 10 refills : SST-CN-R10

MANUAL WIRE FEEDER

Manual Wire feeder for diameter wire from 0.2mm up to 0.6mm, indispensable for small diameter.



SST-GF

ELECTRODES

		Quantity
ELA20-1070-10	Lase-1 electrodes Ø 1.0 x 70 mm (x10)	2
ELA20-1670-10	Lase-1 electrodes Ø 1.6 x70 mm (x10)	2
ELA20-2470-10	Lase-1 electrodes Ø 2.4 x70 mm (x10)	2

WELDING WIRES

	Welding Wires (per meter)	
SST-12330-03	Laser welding wire 1,2330 (P20) - Ø0.3	5
SST-12330-06	Laser welding wire 1,2330 (P20) - Ø0.6	5
SST-12344-03	Laser welding wire 1,2344 (H13) - Ø0.3	5
SST-12344-06	Laser welding wire 1,2344 (H13) - Ø0.6	5
SST-14430-03	Laser welding wire 1,4430 (316L) - Ø0.3	5
SST-14430-06	Laser welding wire 1,4430 (316L) - Ø0.6	5

DEMONSTRATION

To view a Lase One demonstration, visit www.sstmicrowelding.com/en/videos

Please give us a call for additional size wires: 847/808-9400 / info@engis.com



Mold Medic Supplies

WELDING ROD/WIRE MATERIAL

Item No.	Material	Diameter	Length
W4001-0.8	P-20	0.032"	78-3/4"
W4001-0.6	P-20	0.023"	78-3/4"
W4001-0.4	P-20	0.015"	78-3/4"
W4002-0.8	P-21	0.032"	78-3/4"
W4003-0.8	H-13	0.032"	78-3/4"
W4003-0.6	H-13	0.023"	78-3/4"
W4003-0.3	H-13	0.011"	78-3/4"
W4004-0.8	D2,A2	0.032"	78-3/4"
W4004-0.6	D2,A2	0.023"	78-3/4"
W4004-0.4	D2,A2	0.015"	78-3/4"
W4005-0.8	STAVAX	0.032"	78-3/4"
W4005-0.6	STAVX	0.023"	78-3/4"
W4006-0.8	M2,D2,S7	0.032"	78-3/4"
W4006-0.6	M2,D2,S7	0.023"	78-3/4"
W4006-0.4	M2,D2,S7	0.015"	78-3/4"
W4007-0.8	RIGOR	0.032"	78-3/4"
W4008-0.8	ORVAR	0.032"	78-3/4"
W4009-0.8	IMPAX	0.032"	78-3/4"
W4010-0.8	MAS-1	0.032"	78-3/4"



Metal Ribbon

Item No.	Material	Hardness (Rc)	Size (in)
W2004	P-20	30-50	.196x.004x40
W2004-1	P-20	30-50	.196x.008x40
W2002	P-21	38-40	.196x.004x40
W2002-1	P-21	38-40	.196x.008x40
W2005	420SS	30-33	.196x.004x40
W2005	420SS	30-33	.196x.008x40

Powder Metal

Item No.	Material	Hardness (Rc)	Quantity
W2031	P-20	30-50	50 grams
W2033	P-21	38-40	50 grams
W2032	420SS	30-33	50 grams

Paste Metal

Item No.	Material	Hardness (Rc)	Size (in)
W2033-1	P-21	38-40	50 grams
W2032-1	420SS	30-33	50 grams

Porous Metal

Item No.	Material	Thickness	Size (in)
W2054	420SS	.027"	.196x40
W2051	316LSS	.027"	2x3

Yarn Metal

Item No.	Material	Description	Unit
W2062	P-20	Steel Wool Type	Plastic Jar
W2065	P-21	Steel Wool Type	Plastic Jar

ELECTRODES

Mold Medic			Magnetic		
Number	Description	Size	Number	Description	Size
W1009	Pointed, .078" Diameter	2" long	W1015	Round, .078" Diameter	2" long
W1010	Round, .078" Diameter	2" long	W1016	Round, .118" Diameter	2" long

Please give us a call for additional sizes: 847/808-9400 / info@engis.com





INFO@ENGIS.COM
847/808-9400



**Hyprez® Lapping/
Polishing Systems**

Beginning-to-end flat finishing systems – machines, plates, pads, diamond powders, slurries, lubricants and other accessories – plus customized equipment, specialized formulas, testing labs and technical support for process and technology development.

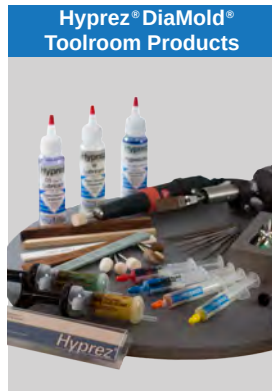

**Hyprez® DiaMold®
Toolroom Products**

Comprehensive line of diamond polishing compounds, abrasive stones, sticks, bobs, brushes and files – plus powered hand finishing systems for every toolroom application.



**Engis® Single-Pass Bore
Finishing Systems**

Single-pass bore finishing systems-standard models and custom machines-plus diamond and CBN plated finishing tools, parts holders/ fixtures and integrated automation systems.

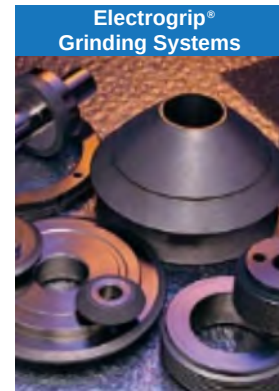

**ElectroGrip®
Grinding Systems**

Advanced superabrasive grinding, cutting and dressing systems utilizing diamond and CBN materials. Specializing in the aerospace, medical, ceramic, automotive, and composite industries.